



SHERWOOD INDUSTRIES IS AN ENVIRONMENTALLY RESPONSIBLE COMPANY. THIS MANUAL IS PRINTED ON RECYCLED PAPER.

PLEASE KEEP THESE INSTRUCTIONS FOR FUTURE REFERENCE



PELLET STOVE

# EF THERMO 28 TECHNICAL MANUAL



CE<sub>2008</sub>

**PLEASE READ THIS ENTIRE MANUAL BEFORE INSTALLATION AND USE OF THIS PELLET-BURNING ROOM HEATER. FAILURE TO FOLLOW THESE INSTRUCTIONS COULD RESULT IN PROPERTY DAMAGE, BODILY INJURY OR EVEN DEATH.**

**Contact your building or fire officials about restrictions and installation inspection requirements in your area.**

**50-878**

# TABLE OF CONTENTS

---

Safety Warnings & Recommendations.....	3
Specifications.....	5
Rating Label Location:.....	5
EF Thermo Data.....	5
Appliance Dimensions.....	6
Safety Devices.....	7
Installation.....	9
Deciding Where to Locate your Pellet Appliance.....	9
Removing Your New Stove From the Pallet.....	9
Slider/Damper Operation.....	9
Installation of Expansion Tank.....	10
Clearances to Combustibles.....	11
Alcove Clearances.....	11
Vent Termination Requirements.....	12
Water Line Schematic.....	13
Horizontal Through Wall Installation.....	14
Through Wall Installation.....	15
Inside Vertical Installation.....	16
Outside Vertical Installation.....	17
Thermostat Installed.....	18
Mobile Home Installation.....	18
Fresh-Air Connections.....	18
Troubleshooting.....	19
Fuses:.....	21
Control Board Functions.....	21
Wiring Diagram.....	22
Parts List.....	23
Parts Diagram - Components.....	24
Parts Diagram - Body.....	25
Installation Data Sheet.....	26

**\* This manual is designed for the technician in conjunction with the owner's manual. \***

# **SAFETY WARNINGS & RECOMMENDATIONS**

Please read this entire Technical Manual before installing or operating your ENVIRO Pellet Stove. Failure to follow these instructions may result in property damage, bodily injury or even death. Any unauthorized modification of the appliance or use of replacement parts not recommended by the manufacturer is prohibited. All national and local regulations and European Standards shall be complied with when operating this appliance.

**Caution:** Do not connect to any air distribution duct or system.

**IMPORTANT:** The heated water from this unit is not for human consumption, but for heating potable water through heat exchange only.

**Warning:** Never place wood, paper, furniture, drapes or other combustible materials within 80cm (31½") of the front of the unit, 20cm (7⅞") from each side, and 10cm (4") from the back of the unit. Do not let children or pets touch it when it is hot.

To prevent the possibility of a fire, ensure that the appliance is properly installed by adhering to the installation instructions. An ENVIRO dealer will be happy to assist you in obtaining information with regards to your local building codes and installation restrictions.

**FIRE EXTINGUISHER AND SMOKE DETECTION:** All homes with a pellet burning stove should have at least one fire extinguisher in a central location known to all in the household. Smoke detectors should be installed and maintained in the room containing the stove. If it sounds the alarm, correct the cause but do not deactivate. You may choose to relocate the smoke detection device within the room; DO NOT REMOVE THE SMOKE DETECTOR FROM THE ROOM.

**CHIMNEY OR RUN AWAY FIRE:** Call local fire department. Close the draft fully. Extinguish the fire in the burn pot liner with a cup of water and close the door. Examine the flue pipes, chimney, attic, and roof of the house, to see if any part has become hot enough to catch fire. If necessary, spray with fire extinguisher or water from the garden hose. **IMPORTANT:** Do not operate the stove again until you are certain the chimney and its lining have not been damaged.

**IN THE EVENT OF A MALFUNCTION:** Turn the water heater feed OFF. Push the ON/OFF button located on the control panel. Have the water heater inspected and serviced by a qualified service technician.

**OPERATION:** The door and ash drawer must be kept closed when the unit is in operation to prevent fume spillage and for proper and safe operation of the pellet stove. Also ensure all gaskets on the door are checked and replaced when necessary. **Do not operate at water pressure below 0.5 bar.**

**FUEL:** This pellet stove is designed and approved to only burn wood pellet fuel with up to 3% ash content. Dirty fuel will adversely affect the operation and performance of the unit and may void the warranty. Check with your dealer for fuel recommendations. Never use gasoline, gasoline-type lantern fuel, kerosene, or similar liquids to start the fire. Keep all such liquids well away from the pellet stove while it is in use.

**THE USE OF CORDWOOD IS PROHIBITED BY LAW.**

**SOOT:** Operation of the stove with insufficient combustion air will result in the formation of soot which will collect on the glass, the heat exchanger, the exhaust vent system, and may stain the outside of the house. This is a dangerous situation and is inefficient. Frequently check your stove and adjust the slider/damper as needed to ensure proper combustion. **See: "SLIDER/DAMPER SETTING".**

**CLEANING:** There will be some build up of fly ash and small amounts of creosote in the exhaust. This will vary due to the ash content of the fuel used and the operation of the stove. It is advisable to inspect and clean the exhaust vent semi-annually or every two tons of pellets.

The appliance, flue gas connector and the chimney flue require regular cleaning. Check them for blockage prior to re-lighting after a prolonged shut down period. Have your unit and venting checked/cleaned/serviced annually by a qualified service technician to prevent excess build-up of dangerous creosote deposits as well as to ensure proper operation and efficiency of this appliance.

Do not use abrasive cleaners to clean the surface or any part of the stove.

# **SAFETY WARNINGS & RECOMMENDATIONS**

**ASHES:** Disposed ashes should be placed in a metal container with a tight fitting lid. The closed container of ashes should be on a non-combustible surface, well away from all combustible materials pending final disposal. If the ashes are disposed of by burial in soil or otherwise locally dispensed, they should be retained in the closed container until all cinders have thoroughly cooled before disposing of them.

**ELECTRICAL:** **The use of a surge protected power bar is recommended.** The unit must be grounded. The grounded electrical cord should be connected to a standard 220-240 volts (3.3 Amps), 50 hertz electrical outlet and also must be accessible. If this power cord should become damaged, a replacement power cord must be purchased from the manufacturer or a qualified ENVIRO dealer. Be careful that the electrical cord is not trapped under the appliance and that it is clear of any hot surfaces or sharp edges. This unit's maximum power requirement is 800 watts.

**GLASS:** Do not abuse the glass by striking or slamming the door. Do not attempt to operate the stove with broken glass. The stove uses ceramic glass. Replacement glass must be purchased from an ENVIRO dealer. Do not attempt to open the door and clean the glass while the unit is in operation or if glass is hot. To clean the glass, use a soft cotton cloth and mild window cleaner, gas or wood stove glass cleaner, or take a damp paper towel and dip into the fly ash. This is a very mild abrasive and will not damage the glass.

**KEEP ASH PAN FREE OF RAW FUEL.** DO NOT PLACE UNBURNED OR NEW PELLET FUEL IN ASH PAN. A fire in the ash pan may occur.

**INSTALLATION:** Contact your local building or fire official to obtain a permit and any information on installation restrictions and inspection requirements for your area.

It is recommended that the unit be secured into its position in order to avoid any displacement.

Be sure to maintain the structural integrity of your home when passing a vent through walls, ceilings, or roofs. It is recommended that the unit be secured into its position in order to avoid any displacement. This appliance must be installed on a floor with an adequate load bearing capacity. If an existing construction doesn't meet these prerequisite suitable measures (e.g. load distributing plate) must be taken to achieve it.

DO NOT INSTALL A FLUE DAMPER IN THE EXHAUST VENTING SYSTEM OF THIS UNIT.  
DO NOT CONNECT THIS UNIT TO A CHIMNEY FLUE SERVING ANOTHER APPLIANCE.

**FRESH AIR:** Outside Fresh Air intake is strongly recommended. Failure to install intake air may result in the unit smoking during power failures as well as improper combustion. Fresh Air must be connected to all units installed in "Air Tight Homes" or where required by local codes.

Consider all large air moving devices when installing your unit and provide room air accordingly. NOTE: Extractor fans when operating in the same room or space as the appliance, may cause problems. Limited air for combustion may result in poor performance, smoking and other side effects of poor combustion.

The stove's exhaust system works with negative combustion chamber pressure and a slightly positive chimney pressure. It is very important to ensure that the exhaust system be sealed and airtight. The ash pan and viewing door must be locked securely for proper and safe operation of the pellet stove.

Do not burn with insufficient combustion air. A periodic check is recommended to ensure proper combustion air is admitted to the combustion chamber. Setting the proper combustion air is achieved by adjusting the slider damper located on the left side of the stove.

Minor soot or creosote may accumulate when the stove is operated under incorrect conditions such as an extremely rich burn (black tipped, lazy orange flames).

If you have any questions with regards to your stove or the above-mentioned information, please feel free to contact your local dealer for further clarification and comments.

**SINCE SHERWOOD INDUSTRIES LTD. HAS NO CONTROL OVER THE INSTALLATION OF YOUR STOVE, SHERWOOD INDUSTRIES LTD. GRANTS NO WARRANTY IMPLIED OR STATED FOR THE INSTALLATION OR MAINTENANCE OF YOUR STOVE. THEREFORE, SHERWOOD INDUSTRIES LTD. ASSUMES NO RESPONSIBILITY FOR ANY CONSEQUENTIAL DAMAGE(S).**

**SAVE THIS INSTRUCTION MANUAL FOR FUTURE REFERENCE**

# SPECIFICATIONS

## **RATING LABEL LOCATION:**

The rating label is located on the hopper lid.

## **EF THERMO DATA:**

Necessary draught	34.8 Pa (0.348 mbar)
Mass of Appliance	157 Kg
Minimum required load bearing capacity of the floor	247 Kg
Water content	17.3 liters
Exhaust gas temperature at nominal heat output	230°C
Exhaust gas temperature at minimum heat output	120°C
Exhaust mass flow at nominal heat output	7.5 g/s
Exhaust mass flow at minimum heat output	8.0 g/s
Flue pipe diameter	80 mm
Space heating output	to be determined by Lab Testing KW
Water heating output	to be determined by Lab Testing KW
Nominal heating output	25 kW
Heat output range	2.5 kW - 25 kW
Combustion period at Q <sub>N</sub>	12 hours
Setting range for the temperature controller	30°C - 75°C
Fuel (type, size, water content)	Wood pellets, 6 mm dia. maximum, <8% W.C.
Hopper capacity	77.75 liters (55 Kg)
Hopper filling opening	440 mm x 320 mm
Auxiliary power requirements	800 W
Test pressure	4.5 bar
Operating pressure	0.5 bar - 2.5 bar
Maximum water pressure	3.0 bar
Maximum water temperature	90°C
Burn Rate	1.0 - 4.5 Kg/hr
Maximum Power Requirement	800 watts
Voltage Rating Range	220-240 volt at 50 Hz
Amperage Rating	3.3 Amp

Table 1

# SPECIFICATIONS

## APPLIANCE DIMENSIONS:

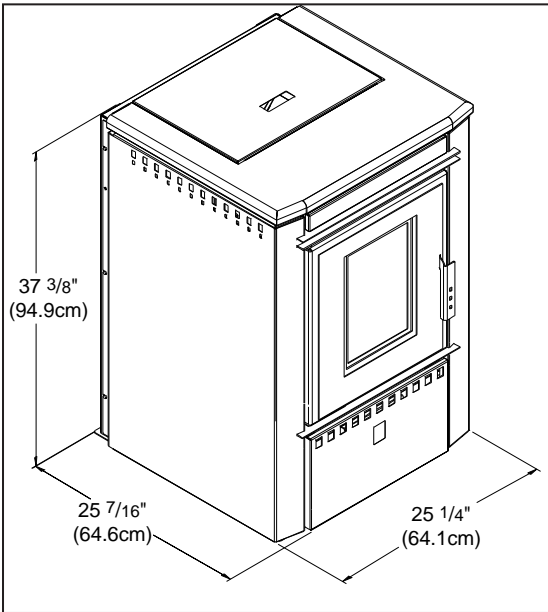

Figure 1

### UNIT DIMENSIONS

HEIGHT: 37 <sup>3</sup>/<sub>8</sub>" (949 mm)

WIDTH: 25 <sup>1</sup>/<sub>4</sub>" (641 mm)

DEPTH: 25 <sup>7</sup>/<sub>16</sub>" (646 mm)

### HEARTH PAD:

WIDTH: 25 <sup>1</sup>/<sub>4</sub>" (641 mm)

DEPTH: 31 <sup>3</sup>/<sub>16</sub>" (793 mm)

[6" (152.4 mm) in front of unit]

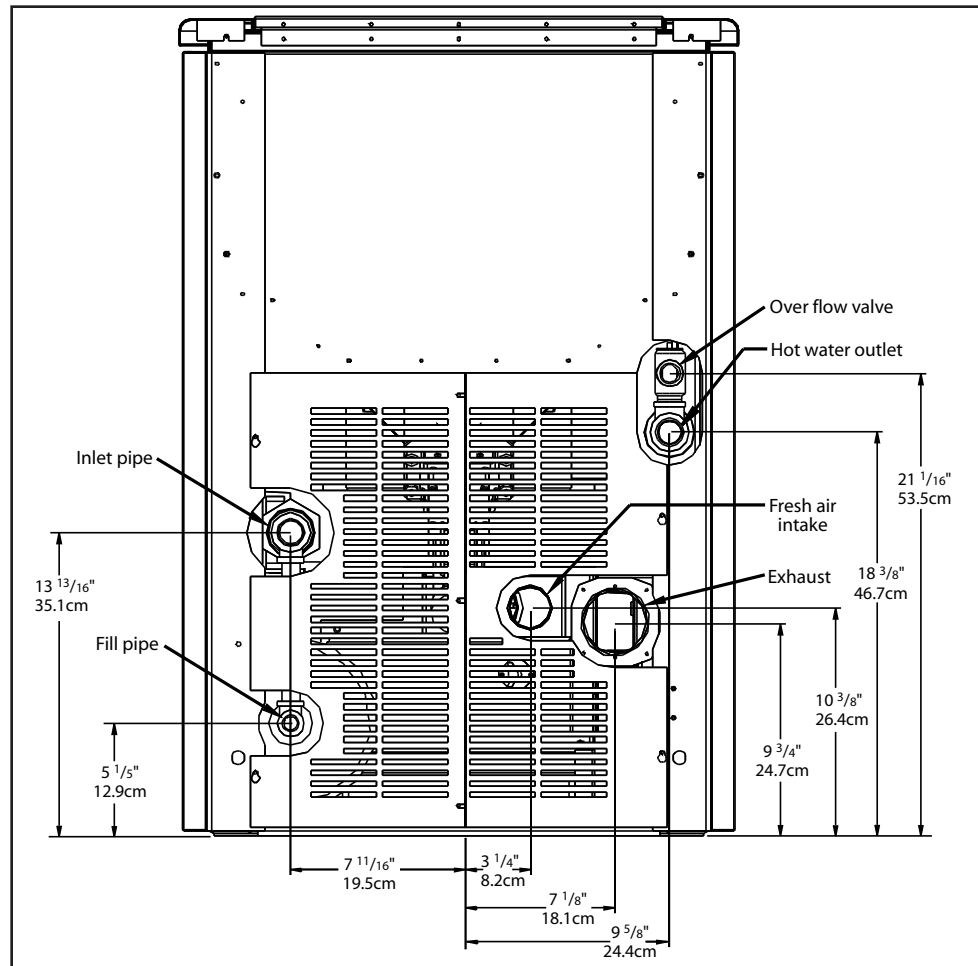

Figure 2

# SPECIFICATIONS

## SAFETY DEVICES:

**Air Bleeder Valve** (shown in Figure 3):  
Located under unit top of the unit.

To remove the top follow these steps (refer to Figure 4):

1. Open hopper lid and remove the two (2) screws at the front.
2. Loosen the two (2) screws at the back of the top.
3. Remove top.
4. Replace the top by using the reverse of the method used to remove it.

Refer to Figure 5 and 6 for the following safety devices.  
See next page to remove cabinet sides.

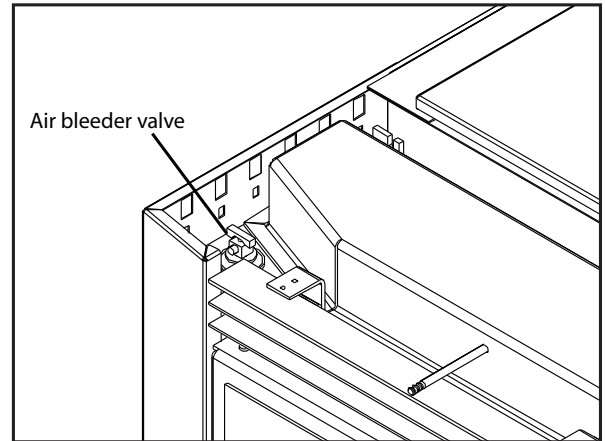

Figure 3

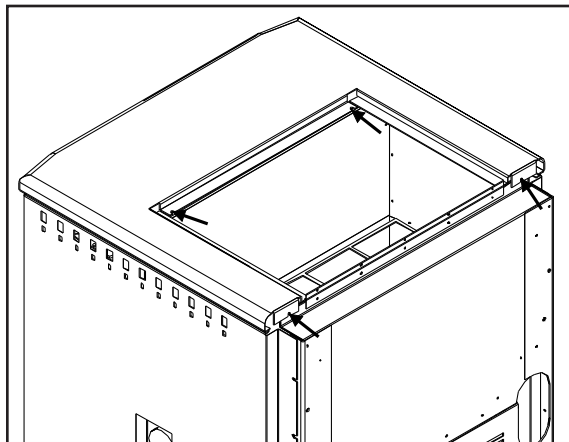

Figure 4

**WARNING: DO NOT TAMPER, REMOVE, OR BYPASS THE FOLLOWING SAFETY DEVICES. DOING SO COULD RESULT IN PROPERTY DAMAGE, BODILY INJURY OR EVEN DEATH.**

**Low Pressure Switch:** Located behind right cabinet side.

**Water Temperature Limit Switch:** Located behind right cabinet side.

**Pressure Relief Valve:** Located behind left cabinet side.

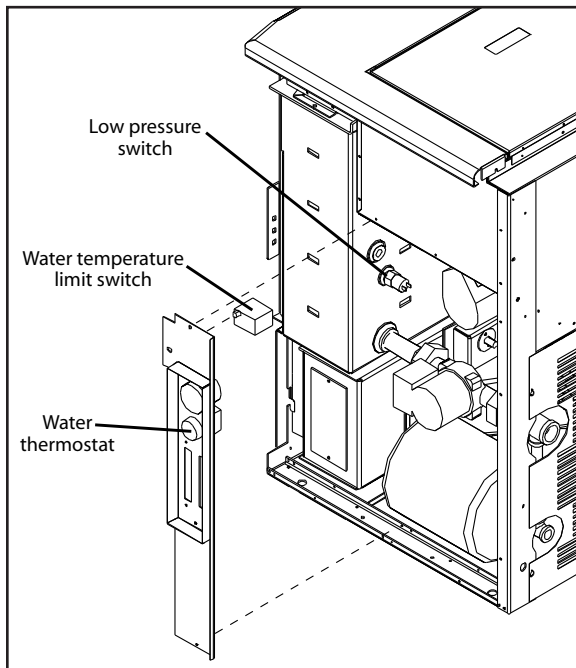

Figure 5

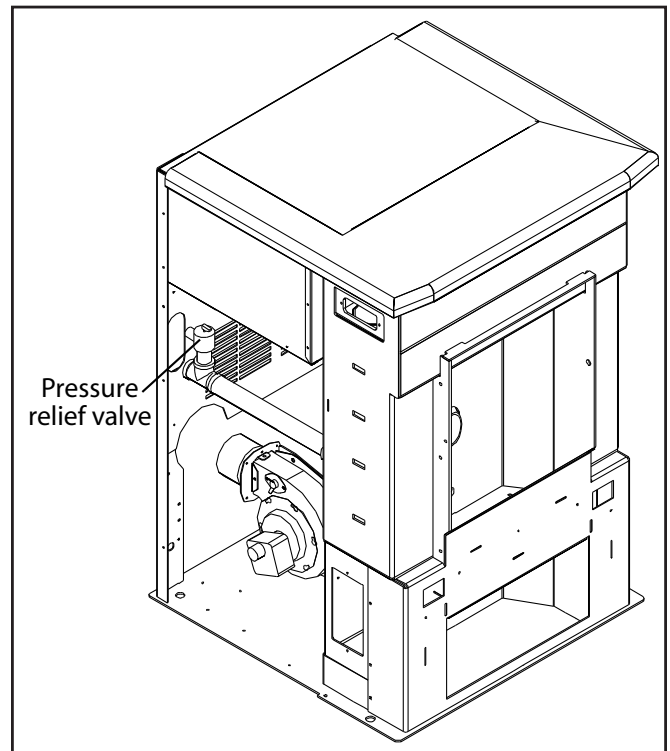

Figure 6

# SPECIFICATIONS

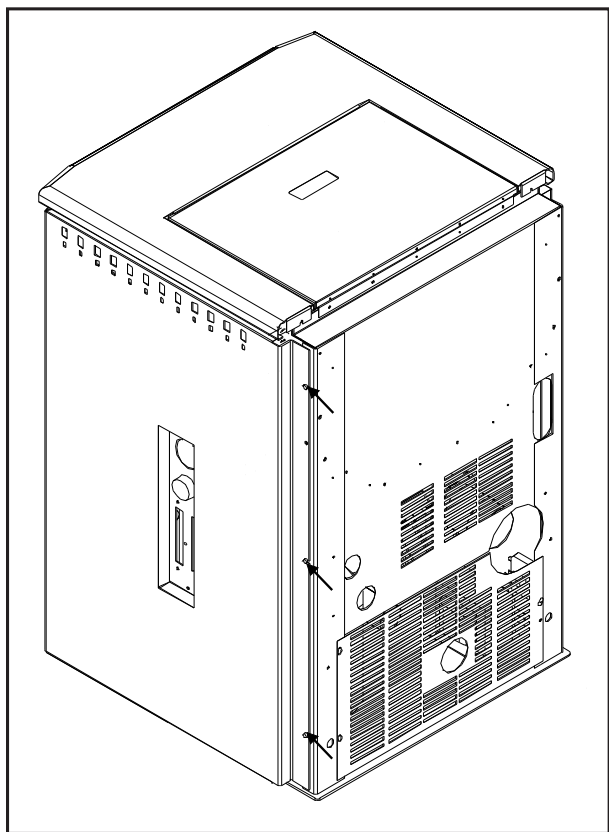

Figure 7

To remove the cabinet sides, follow these steps:

1. Loosen the three (3) screws from both sides on the back of the appliance (see Figure 7).
2. Remove the ash drawer cover (see Figure 8).
3. Remove the four (4) screws, two on each side, under the ash drawer holding the cabinet sides on (see Figure 9).
4. Slide cabinet side forward and out.
5. Replace cabinet sides by using the reverse of the method used to remove them.
6. Replace the ash pan cover.

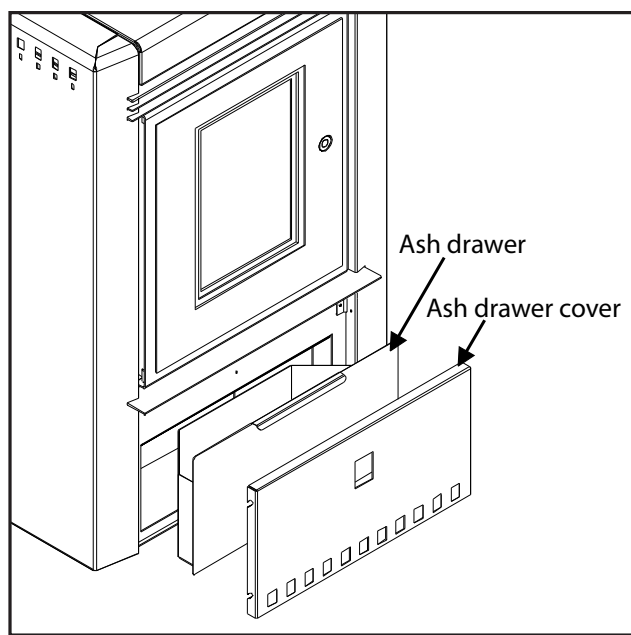

Figure 8

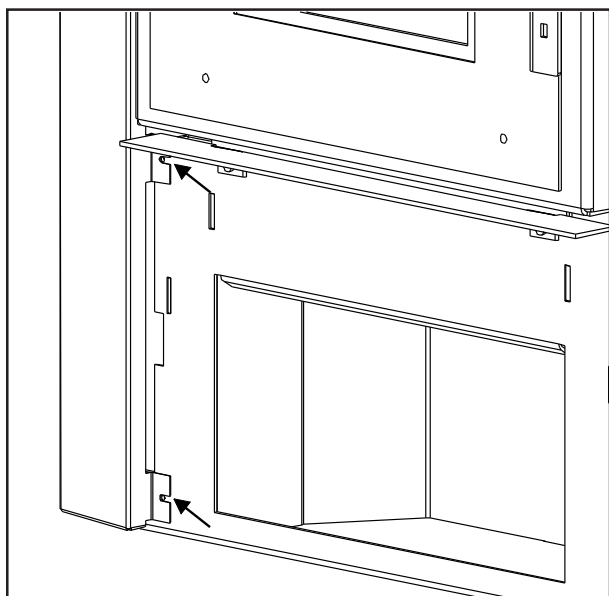

Figure 9



# INSTALLATION

---

All local regulations, including those referring to national and European Standards need to be complied with when installing this appliance.

## **DECIDING WHERE TO LOCATE YOUR PELLET APPLIANCE:**

---

1. Check clearances to combustibles to the unit and for the venting as per the pellet vent manufacturer's installation instructions.
2. Do not obtain combustion air from an attic, garage or any unventilated space. Combustion air may be obtained from a ventilated crawlspace.
3. Do not install the stove in a bedroom.
4. You can vent the stove through an exterior wall behind the unit or connect it to an existing masonry or metal chimney (must be lined if the chimney is over 6" in diameter, or over 28 inches<sup>2</sup> cross sectional area). An interior vent can be used with approved pipe passing through the ceiling and roof.
5. Locate the stove in a large and open room that is centrally located in the house. This will optimize heat circulation.
6. The power cord is 8 feet (2.43 m) long and may require a grounded extension cord to reach the nearest electrical outlet.

## **REMOVING YOUR NEW STOVE FROM THE PALLET:**

---

To remove your new stove from its pallet you must remove both cabinet sides. This is done by the following steps (refer to Figures 7, 8, and 9 in the section Specifications - Safety Devices):

1. Loosen the three (3) screws from both sides on the back of the appliance.
2. Remove the ash pan cover.
3. Remove the four (4) screws, two (2) on each side, next to the ash pan holding the cabinet sides on.
4. Slide cabinet sides forward and out.
5. Remove the two (2) screws, one on each side, that are holding the base of the unit to the pallet.
6. Remove the unit from the pallet.
7. Replace cabinet sides using the reverse of the method used to remove them.
8. Replace the ash pan cover.

## **SLIDER/DAMPER OPERATION:**

---

This is used to regulate the airflow through the pellet stove.

- On the low heat output settings, push the slider all the way in (see Figure 10).
- On the high heat output pull the slider out or until a good fire is achieved. A good fire (see Figure 11) is in between a fire with lazy black tipped flames and a forced fire (very quick, shorter flames). A good fire is the most efficient and will have a bright and active flame.
- Slider should be set at a hot magnehelic reading of 0.14" W.C. (34 Pa) for firebox vacuum.

# INSTALLATION

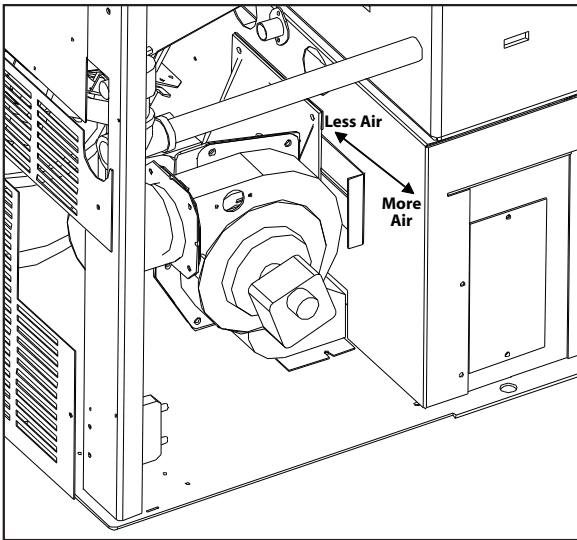

Figure 10



Figure 11

## INSTALLATION OF EXPANSION TANK:

The expansion tank **MUST** be installed before this unit can be used.

1. Remove the expansion tank from the box located in the hopper.
2. Loosen the four (4) screws pointed out in Figure 12. Lift the back grill up and remove it from the unit.
3. Apply thread sealant to the fitting point out in Figure 13 then tighten the expansion tank onto the fitting.

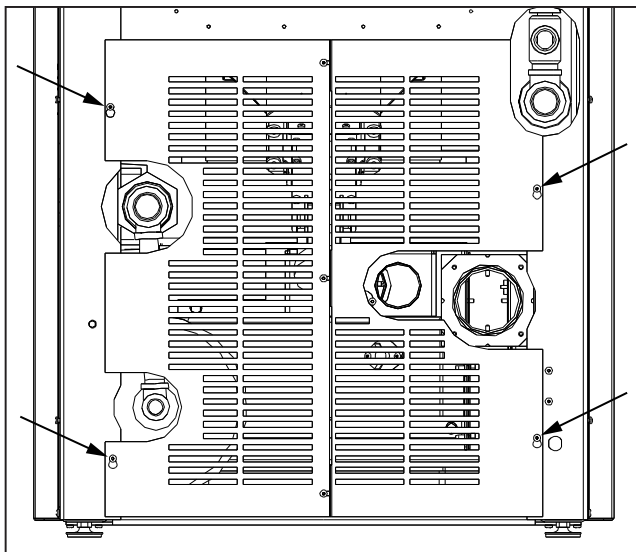

Figure 12

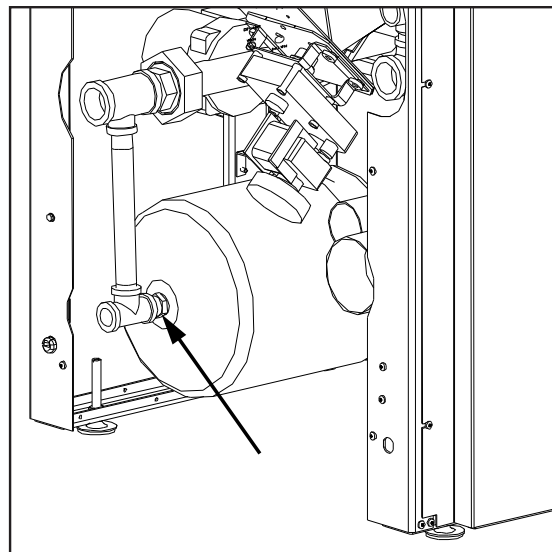
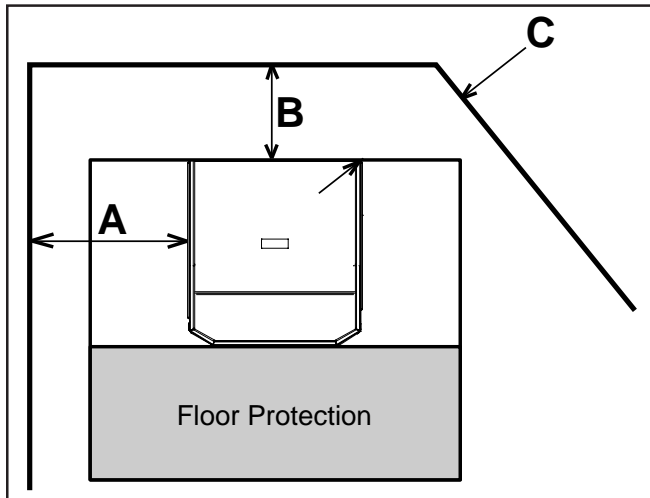

Figure 13

# INSTALLATION

## CLEARANCES TO COMBUSTIBLES:



**Figure 14**

This unit can be installed on a combustible floor due to the built in pedestal hearth pad (for example linoleum, hardwood flooring). If combustible flooring is underneath the unit 6 inches (153 mm) on either side and to the front must be protected by non-combustible material. If this unit is to be installed onto a carpeted surface, a hearth pad must be used for stability.

NOTE: These dimensions are minimum clearances but it is recommended that you ensure sufficient room (20" [508 mm]) on either side) for servicing, routine cleaning and maintenance.

Do not block any of the air intake grills.

Maintain these clearances to combustibles.

<b>A)</b> Side wall to unit	6 inches	(153 mm)
<b>B)</b> Back wall to unit	1 inch	( 25 mm)
<b>C)</b> Adjacent wall to corner of unit	1 inch	( 25 mm)
- Mantle (Hearth Mount)	8 inches	(203 mm)

## ALCOVE CLEARANCES:

This unit may be installed in an alcove. Maintain clearances to combustibles.

Minimum Alcove width	36 inches	( 914 mm)
Minimum alcove height	48 inches	(1220 mm)
Maximum alcove depth	30 inches	( 762 mm)

**Install vent at clearances specified by the vent manufacturer.**

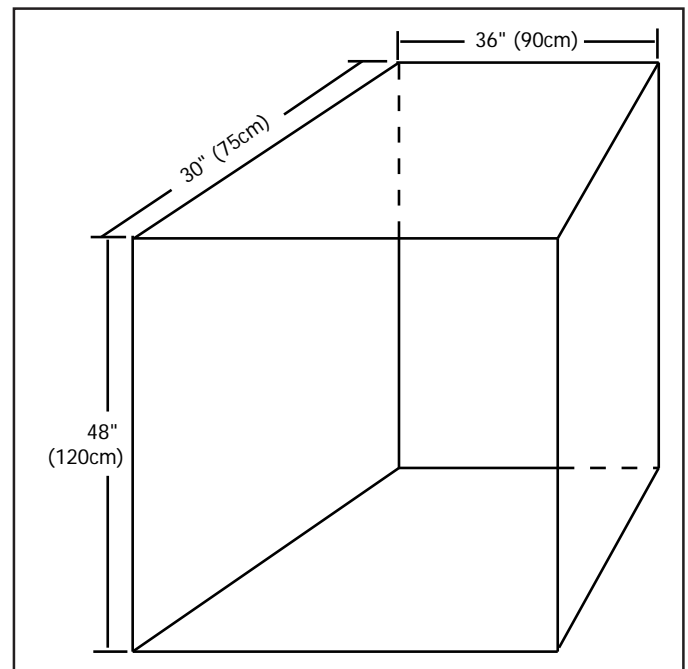

**Figure 15**

# INSTALLATION

## VENT TERMINATION REQUIREMENTS:

IT IS RECOMMENDED THAT YOUR PELLET STOVE BE INSTALLED BY AN AUTHORIZED DEALER/INSTALLER.

Table 2: Use in conjunction with Figure 16 for allowable exterior vent termination locations.

Letter	Minimum Clearance	Description
A	61cm (24 in)	Above grass, top of plants, wood, or any other combustible materials.
B	122 cm (48 in)	Beside/below any door or window that may be opened. (46 cm (18") if outside fresh air install.)
C	30 cm (12 in)	Above any door or window that may be opened. (23 cm (9") if outside fresh air install.)
D	61cm (24 in)	To any adjacent building, fences and protruding parts of the structure.
E	61cm (24 in)	Below any eave or roof overhang
F	30 cm (12 in)	To outside corner.
G	30 cm (12 in)	To inside corner, combustible wall (vertical and horizontal terminations).
H	91 cm (3 ft) within a height of 4.5 m (15 ft) above the meter/regulator assembly	To each side of center line extended above natural gas or propane meter/regulator assembly or mechanical vent.
I	91 cm (3 ft)	From any forced air intake of other appliance
J	30 cm (12 in)	Clearance to non-mechanical air supply inlet to building, or the combustion air inlet to any appliance.
K	61cm (24 in)	Clearance above roof line for vertical terminations.
L	2.13 m (7 ft)	Clearance above paved sidewalk or paved driveway located on public property.

1. Do not terminate the vent in any enclosed or semi-enclosed areas such as a carport, garage, attic, crawlspace, narrow walkway, closely fenced area, under a sundeck or porch, or any location that can build up a concentration of fumes such as stairwells, covered breezeway, etc.

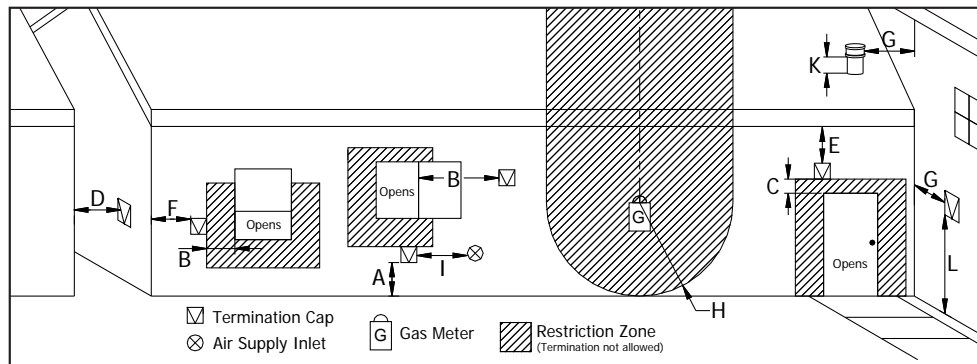

Figure 16: Use in conjunction with Table 2 for allowable exterior vent termination locations.

2. Vent surfaces can become hot enough to cause burns if touched by children. Non-combustible shielding or guards may be required.
3. Termination must exhaust above the inlet elevation. It is recommended that at least five feet of vertical pipe be installed outside when the appliance is vented directly through a wall, to create some natural draft to prevent the possibility of smoke or odor during appliance shut down or power failure. This will keep exhaust from causing a nuisance or hazard from exposing people or shrubs to high temperatures. In any case, the safest and preferred venting method is to extend the vent through the roof vertically.
4. Distance from the bottom of the termination and grade is 30 cm (12 in) minimum. This is conditional upon the plants and nature of grade surface. The exhaust gases are hot enough to ignite grass, plants and shrubs located in the vicinity of termination. The grade surface must not be lawn.
5. If the unit is incorrectly vented or the air to fuel mixture is out of balance, a slight discoloration of the exterior of the house might occur. Since these factors are beyond the control of Sherwood Industries Ltd, we grant no guarantee against such incidents.

**NOTE: Venting terminals shall not be recessed into walls or siding.**



# INSTALLATION

---

## **HORIZONTAL THROUGH WALL INSTALLATION:**

---

The **ENVIRO EF THERMO** can be vented by a couple of different methods.

1. **NOTE:** Use only listed type "PL" or "L" pellet venting products. Failure to use listed components may cause damage or personal injury or death.
2. Choose a location for your stove that meets the requirements stated in this manual and allows installation with the least amount of interference to house framing, plumbing, wiring, etc.
3. **Install a non-combustible hearth pad underneath the unit extending 6 inches (15 cm) in front of and to the sides.**
4. Place the stove 15" (38.1 cm) away from the wall. If the stove is to be set on a hearth pad, set the unit on it.
5. Locate the center of the exhaust pipe on the stove. Extend that line to the wall. Once you have located the center point on the wall, refer to pellet vent manufacturer installation instructions for the correct hole size and clearances to combustibles.
6. Install the wall thimble as per the instructions written on the thimble. Maintain an effective vapor barrier.
7. Install a 2' or 3' (61 or 92 cm) length of 3" (7.6 cm) or 4" (10.2 cm) listed type "PL" or "L" vent pipe into the wall thimble. The pipe should install easily into the thimble.
8. Install the fresh air intake (see the section entitled FRESH AIR CONNECTIONS).
9. Connect the exhaust vent pipe to the exhaust pipe on the stove.
10. All Joints in the vent system shall be fastened with (3) three screws. Seal the connection with high temperature silicone.
11. Push the stove straight back, leaving a minimum of 1" (2.5 cm) clearance from the back of the stove to the wall. Seal the vent pipe to the thimble with high temperature silicone.
12. The pipe must extend at least 12' (30.5 cm) away from the building. If necessary, bring another length of pipe (PL type) to the outside of the home to connect to the first section. Do not forget to place high temperature silicone around the pipe that passes through the thimble.
13. Install a vertical pipe; or, if all requirements for direct venting are met, install vent termination. The stainless steel cap termination manufactured by the vent manufacturer is recommended. However, when the vent terminates several feet above ground level and there are no trees, plants, etc. within several feet, a 45 degree elbow can be used as termination. The elbow must be turned down to prevent rain from entering.

### **NOTE:**

- It is recommended that horizontal through wall installations have 3 to 5 feet (91 to 152 cm) of vertical pipe in the system to help naturally draft the unit in the event of extreme weather or a power outage.
- Some horizontal through wall installations may require a "T" and 3 to 5 feet (91 to 152 cm) of vertical pipe outside the building to help draft the unit. This may be required if a proper burn cannot be maintained, after the stove has been tested and the airflow set. This is due to the back pressure in the exhaust caused by airflow around the structure.
- Follow vent manufacturer's guidelines for installation of venting. High temperature sealant must be used when connecting the vent pipe to the unit's starter pipe. Improper seals at the vent joints may cause combustion byproducts to leak into the room where installed - seal as required.

# INSTALLATION

## THROUGH WALL INSTALLATION:

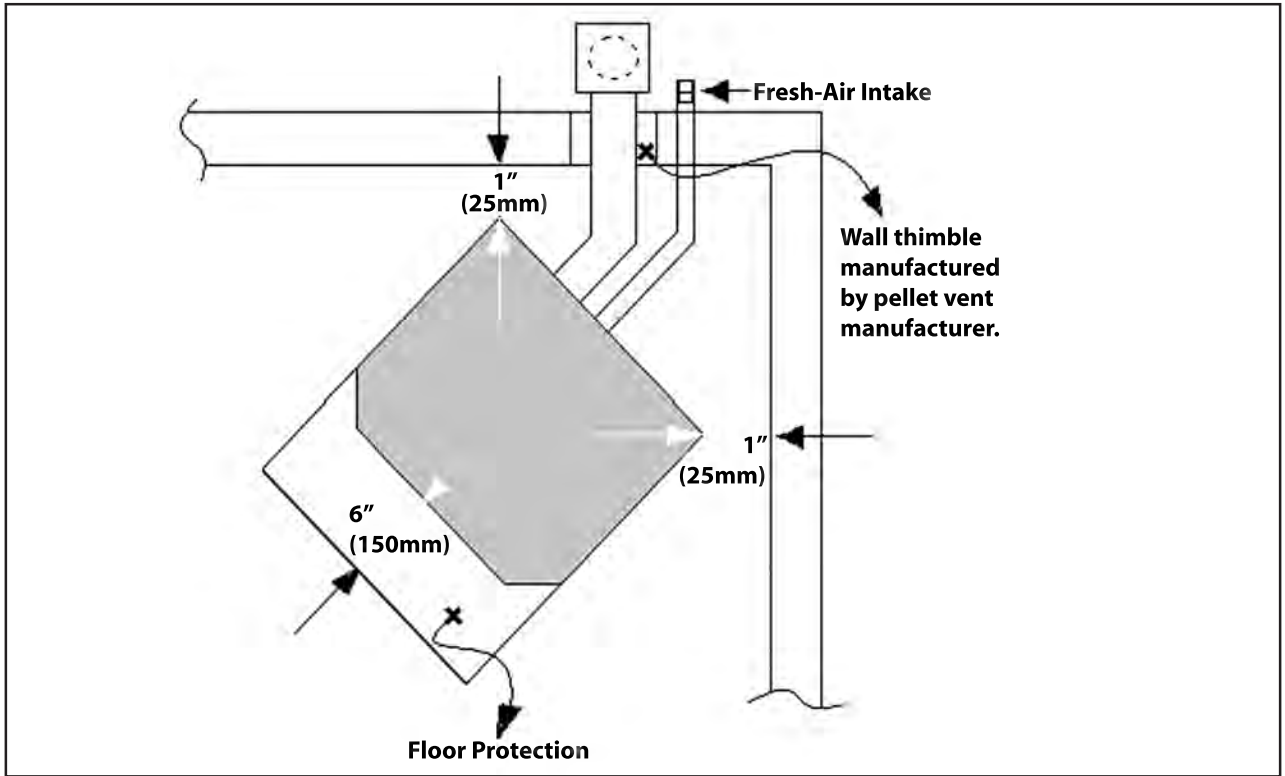

Figure 18

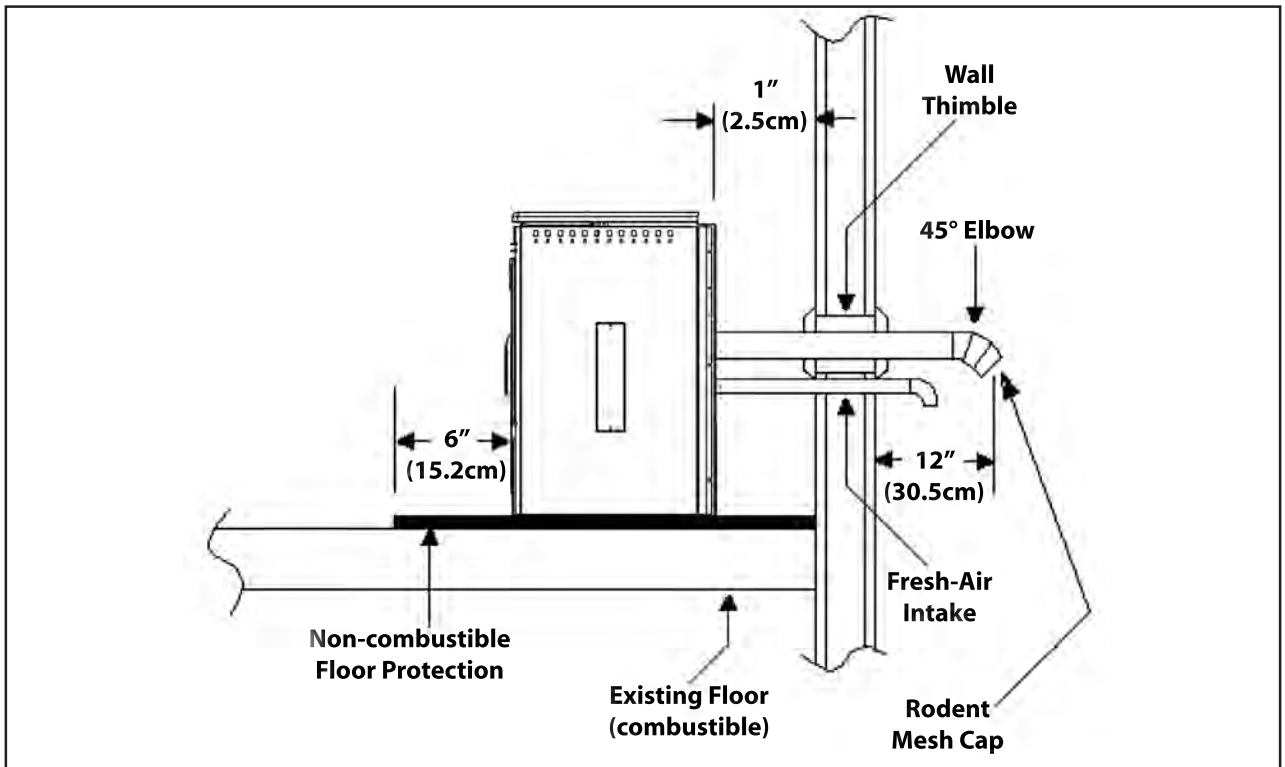

Figure 19

# INSTALLATION

## INSIDE VERTICAL INSTALLATION:

1. Choose a stove location that is ideal. See the section Deciding Where to Locate Your Pellet Appliance.
2. Place a non-combustible hearth pad where necessary.
3. Place the unit on the hearth pad and space it in a manner so when the pellet vent is installed vertically, it will be 3" (76 mm) away from a combustible wall.
4. Locate the center of the fresh air intake pipe on the unit. Match that center with the same point on the wall and cut a hole about 1 5/8" (41 mm) in diameter.
5. Install the fresh-air intake pipe.
6. Install the tee with clean out.
7. Install the pellet vent upward from there. When you reach the ceiling make sure that the vent goes through the ceiling firestop. Maintain a 3" (76 mm) distance to combustibles and keep attic insulation away from the pipe.
8. Finally, extend the pellet vent to go through the roof flashing.
9. Ensure that the rain cap is approximately 36" (914 mm) above the roof.

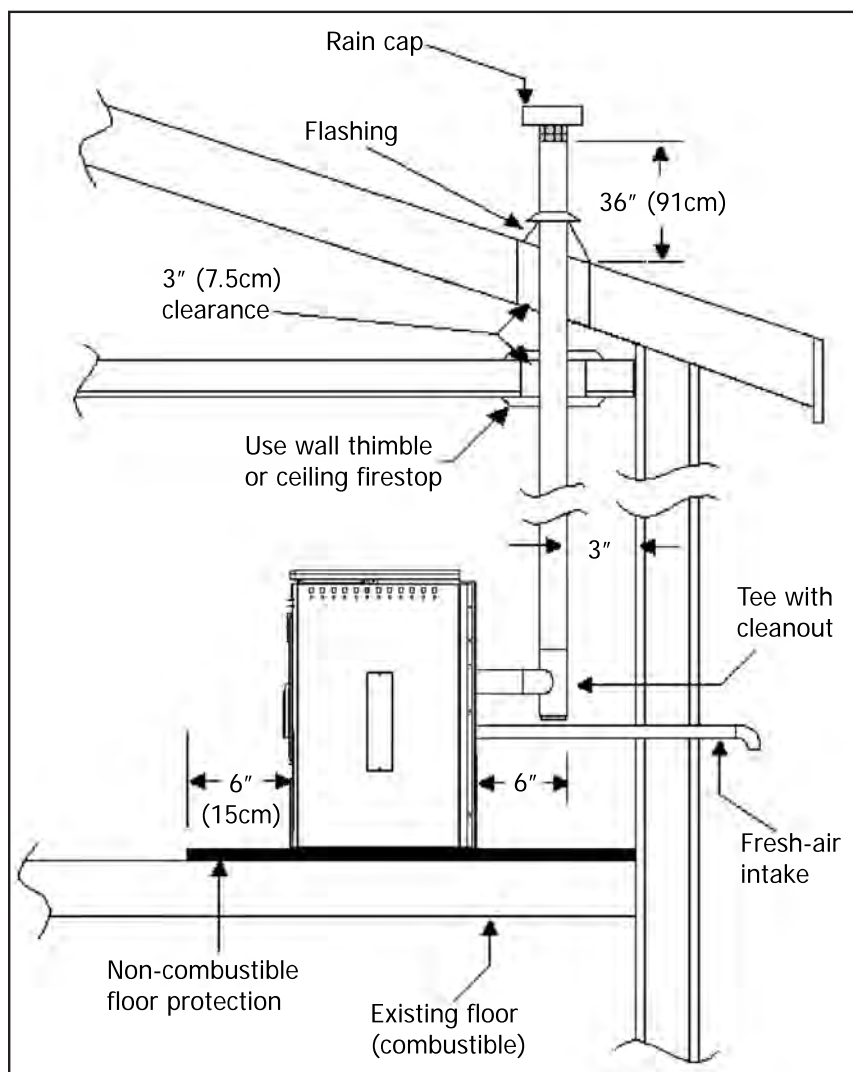

Figure 20



# INSTALLATION

## OUTSIDE VERTICAL INSTALLATION:

To accomplish an outside vertical installation, follow steps 1 through 9 in the Inside Vertical Installation section and then finish it by performing the following:

10. Install a tee with clean out on the outside of the house.
11. Install PL vent upward from the tee. Make sure that you install support brackets to keep the vent straight and secure.
12. Secure the flashing as you go through the roof.
13. Ensure that the rain cap is approximately 36" (914 mm) above the roof.

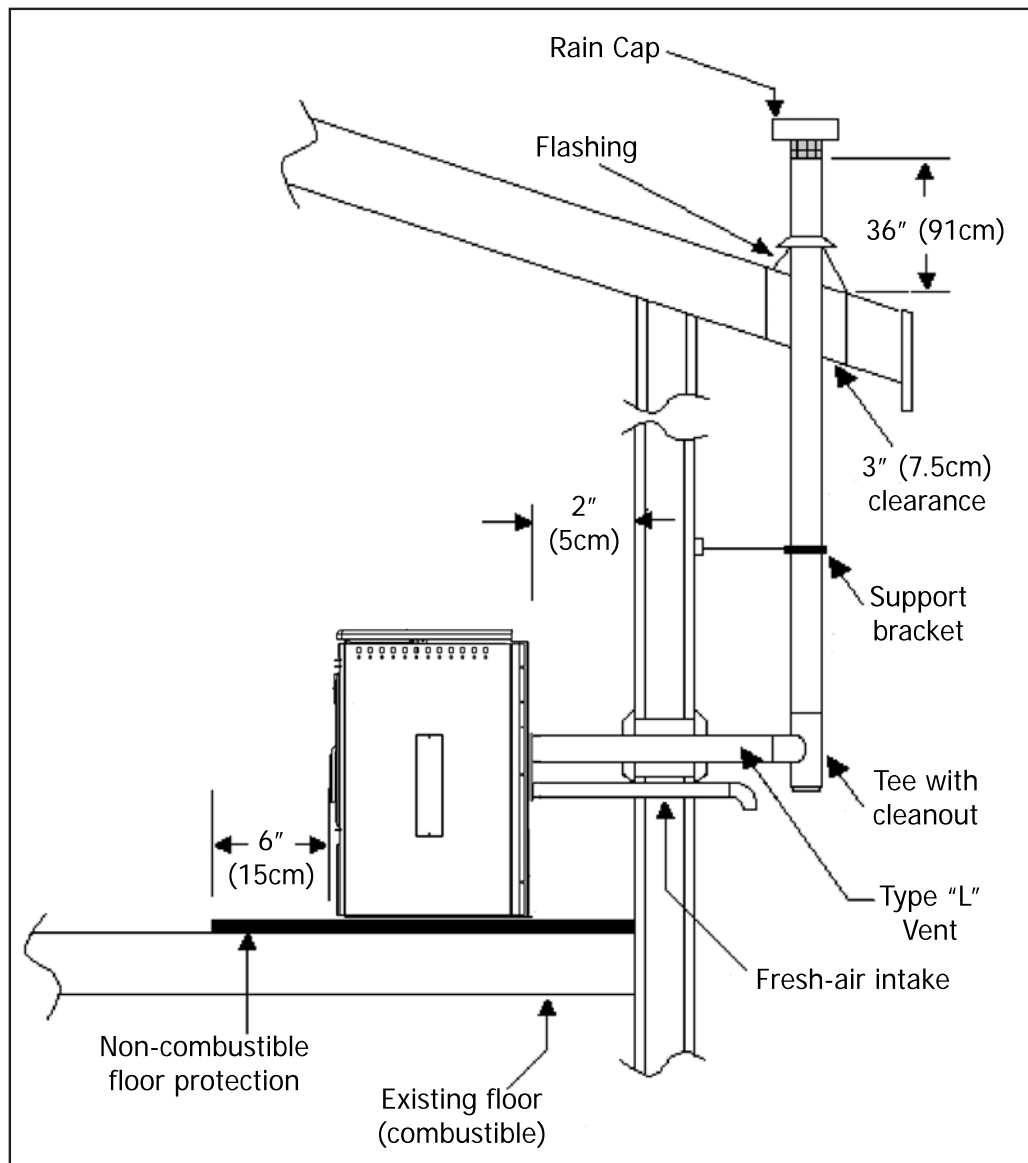

Figure 21

# INSTALLATION

## THERMOSTAT INSTALLED:

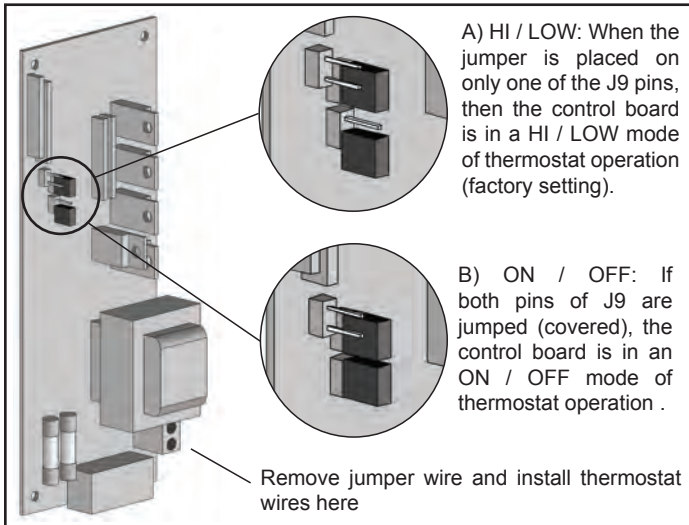

Figure 22

This control board can be placed into two different modes: When the jumper J9 is not jumped then the control board is in a HI / LOW mode operation. If the control board is placed with J9 jumped then the control board is in a ON / OFF mode of operation. In the ON /OFF thermostat mode, the unit will shut OFF when the thermostat is not calling for heat. When the thermostat calls for heat, the unit will go through an ignition sequence once again and relight.

1. Install the wall thermostat (millivolt rated thermostat recommended, or a 12/24 volt rated thermostat set to millivolts) in a location that is not too close to the unit but will effectively heat the desired area.
2. Connect the thermostat using an 18 x 2 gauge wire from the unit to the thermostat.

If the unit has been placed in the HI / LOW mode, the unit will be taken to a low or idle setting when the thermostat is not calling for heat. When the thermostat calls for heat, the unit will go to the setting that is displayed on the control board Heat Indicator. If the heating load is not great enough when the stove is on low, the high limit switch will turn the stove off and the switch will have to be manually reset. To reset the high limit switch, remove the right cabinet side. The switch is found behind the control panel. Avoid setting off the high limit switch.

## MOBILE HOME INSTALLATION:

- Secure the heater to the floor using the two bolt holes supplied in the pedestal.
- CAUTION: THE STRUCTURAL INTEGRITY OF THE MANUFACTURED HOME FLOOR, WALL, AND CEILING/ROOF MUST BE MAINTAINED.**
- Ensure the unit is electrically grounded to the chassis of your home (permanently).
- Do not install in a room where people sleep.
- Outside fresh air is mandatory when installing into airtight homes or manufactured homes.

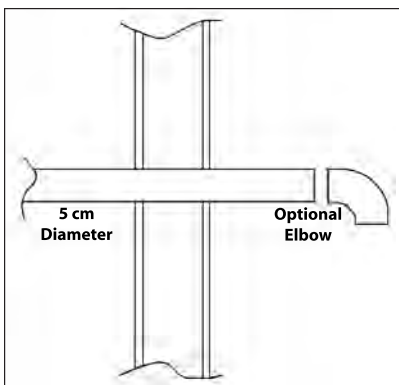

Figure 23

## FRESH-AIR CONNECTIONS:

**NOTE:** Fresh air is mandatory on all units installed in "Mobile Homes" as well as in "Air Tight" homes.

When connecting to an outside fresh-air source, do not use plastic, combustible pipe. Only 2" (5 cm) ID steel, aluminum or copper pipe should be used. It is recommended, when you are installing a fresh-air system, to keep the number of bends in the pipe to a minimum.

# TROUBLESHOOTING

---

## DO NOT:

- Hold the ON / OFF BUTTON; this is a momentary contact switch and can be damaged if held down too long.
- Service the stove with wet hands. The stove is an electrical appliance, which may pose a shock hazard if handled improperly. Only qualified technicians should deal with possible internal electrical failures.
- Do not remove any screws in the firebox without first lubricating them with penetrating oil.

## WHAT TO DO IF:

1. The stove will not start.
2. The stove will not operate when hot.
3. The exhaust blower will not function normally.
4. The convection blower will not function normally.
5. Ignitor : The pellets will not light.
6. The auger motor does not function normally.
7. Control settings (heat level) have no effect on fire.
8. The stove will not shut off.
9. The stove keeps going out.
10. The #2 light is flashing.

**\*NOTE: All troubleshooting procedures should be carried out by qualified technicians or installers.**

### 1. The stove will not start.

- ✓Make sure the stove is plugged in and the wall outlet is supplying power.
- ✓Push the ON /OFF button.
- ✓If the Control Board has been placed in the ON /OFF thermostat mode, then turn the thermostat up to call for heat.
- ✓If the unit still does not start, contact your local service dealer for service.

### 2. The stove will not operate when hot.

- ★Check the hopper for fuel.
- ★Incorrect air damper setting - Excessive air may consume the fire too quickly before the next drop of fuel, leaving completely unburned fuel in the burn pot liner. Insufficient air will cause build up, further restricting the air flow through the Burn Pot Liner. This, in turn, will cause the fuel to burn cold and very slowly. Fuel may build up and smother the fire. **(NOTE: Unit may require a change to the vent system or installation of fresh air to correct Air to Fuel ratio problems).**
- ★Combustion Blower failure - The Combustion Blower is not turning fast enough to generate the proper vacuum in the fire box. Visual Check – is the blower motor turning?
- ★Check Vacuum levels in the firebox with a Magnahelic gauge and an 1/8" tube placed through the small hole under the ash sill (readings must be above .13" W.C. on low fire).  
**Note:** If the motor fails to reach a 0.13" W.C. reading, then replace the Combustion Blower.
- ★Poor Quality Fuel – Insufficient energy in the fuel to produce enough heat to keep the stove burning or operational.
- ★Exhaust Temperature Sensor failure – Bypass sensor located on Exhaust Channel. If stove now operates properly, the unit may require cleaning or a new sensor. Contact your local dealer for service.
- ★The unit may require cleaning. Contact your local dealer for service.
- ★The third red LED light in the heat level indicator light will flash if a fire is not detected or if the fire has gone out.

# TROUBLESHOOTING

---

## 3. The exhaust motor will not function normally.

- ✓Open the left side access panel; check all connections against the wiring diagram.
- ✓Contact your local dealer for service.

## 4. The convection blower will not function normally.

- ★Clean all grill openings at the back and below unit.
- ★Press the fan button. Does the fan come on? Press again to verify that the blower turns on; if not, contact your local dealer for service.

## 5. Ignitor- the pellets will not light.

Everything else in the stove operates but the ignitor will not light the pellets

- ✓Make sure the burn pot liner is up tight and square to the ignitor tube (by pushing the burn pot back against the ignitor tube).
- ✓Check to see if the exhaust blower is operating. If not, contact your local dealer for service.

**NOTE:** The ignitor should be bright orange in color. If not, replace the ignitor.

## 6. The auger motor will not function normally.

- ★Check for obstructions in the hopper system.
- ★Make sure the vacuum switch is closing; open slider to increase vacuum in the firebox.
- ★Call your local dealer for service.

## 7. Control settings (Heat Level) have no effect on the fire.

**NOTE:** If the system light is flashing, the Control Board has complete control of the unit. When the unit's system light becomes solid, then control of the unit is given back to the operator.

- ✓If there is no control of the Heat Level button, make sure the thermostat is calling for heat.
- ✓Call your local dealer for service.

## 8. The stove will not shut off.

- ★If the unit will not shut off, ensure that the thermostat (if equipped) is turned down below the room temperature (thermostat mode in the ON / OFF position).
- ★If the unit is in the HI/LOW mode the unit will not shut off but will go to an idle setting (LOW). Press the ON/OFF button to turn the unit off.
- ★Disconnect one of the brown wires from the exhaust temperature sensor. If the unit continues to operate, contact your local dealer for service.

## 9. The stove keeps going out.

If the stove goes out and leaves fresh unburned pellets or cigarette-like ashes in the burn pot liner, the fire is going out before the stove shuts off.

- ✓Check to see that the Slider / Damper is in the correct position.
- ✓Turn the Heat Level up slightly (poor quality pellets will require slightly higher settings).
- ✓Set the auger trim till the #1 and #5 lights are illuminated.

If the stove goes out and there are partially burned pellets left in the burn pot liner, the stove has shut down due to a lack of air, exhaust temperature, or power failure.

- ★Adjust the Slider / Damper.
- ★Check to see if the stove needs a more complete cleaning.
- ★Did the power go out?

# TROUBLESHOOTING

- ★Contact your local Dealer for service.
- ★Turn the Heat Level up slightly (poor quality pellets will require slightly higher settings).

If the stove goes out and there are no pellets in the liner, the auger is stopping.

✓See "The auger motor will not function normally" and "The exhaust blower will not function normally."

## 10. The #2 light is flashing. (see #8 in Figure 23)

- ★The water temperature high limit switch has tripped. Remove right cabinet side and manually reset the high limit switch.
- ★The low water pressure switch has tripped. Increase the water pressure in the system.

**To reset Circuit Board after a trouble code - push the ON/OFF button**

## FUSES:

F1 is the fuse to the inside of the circuit board controls. If F1 has blown there may have been an input power overload or a short in the convection fan.

F2 fuse closest fuse to the outside edge of the circuit board controls. If fuse F2 has blown then there was a electrical overload problem with one of the following parts: ignitor, auger motor, high limit switch, or exhaust blower.

## CONTROL BOARD FUNCTIONS:

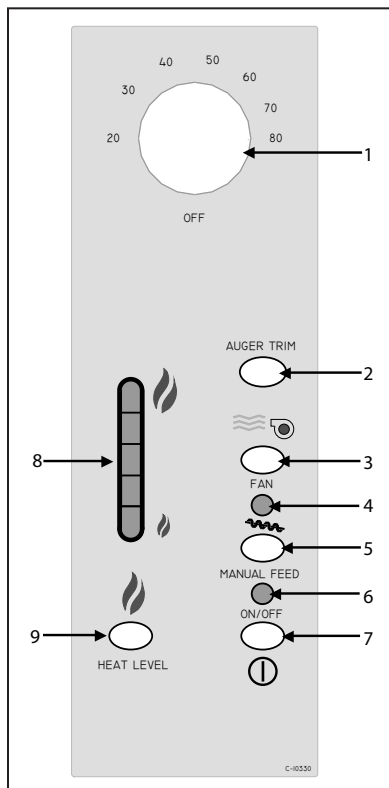
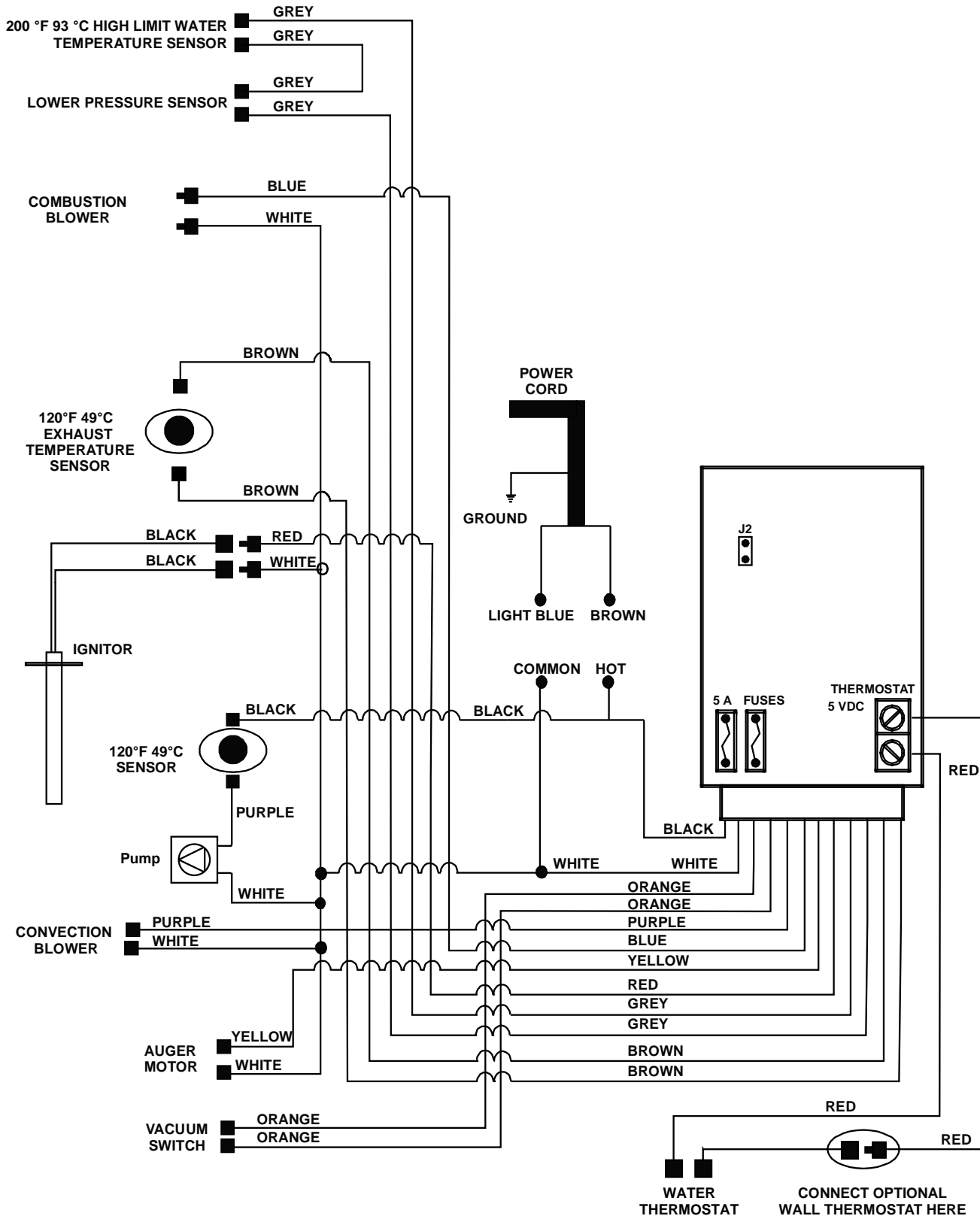

Figure 24

1. **WATER TEMPERATURE DIAL:** Read in degrees Celsius
2. **AUGER TRIM**
3. **CONVECTION BLOWER CONTROL**
4. **AUGER PULSE LIGHT:** This light flashes in conjunction with the auger.
5. **MANUAL AUGER FEED:** If the unit runs out of fuel, this button can be used to "prime the auger system". This button will turn off after 60 seconds and then must be released and pressed again.
6. **SYSTEM LIGHT:** If flashing, the board is under control. If the light is solid, setting can be altered.
7. **ON/OFF BUTTON**
8. **HEAT OUTPUT INDICATOR:** Shows the present heat output setting. Has lights 1 - 5.
9. **HEAT LEVEL ADJUSTMENT:** When pressed, will change the heat setting of the unit from low to high.

**NOTE:** This unit is capable of continuous operation if the heat demand is high enough to require the unit to stay on.

# WIRING DIAGRAM



# PARTS LIST

---

Reference Number	Part Description	Part Number
1	120°F (49°C) exhaust temperature sensor	EC-001
2	Vacuum switch - 220V	EF-017-220V
3	Auger Brass Bushings (Set Of 2)	EF4i-065
4	Hardened Bushing	20-020
5	300 Watt Ignitor - 220V	50-646
6	Tube cleaner rod	50-680
	DIN Owner's Manual	50-877
	DIN Technical Manual	50-878
7	Exhaust Blower AsSEMBLY - 220V	50-900
8	Circuit board - 220V	50-1015
9	Auger Motor-3RPM-220V	50-1024
10	Convection Blower - 220V	50-1025
11	Water Pump	50-1026
12	Low Pressure Switch	50-1027
13	Water Thermostat	50-1028
14	Water High Limit (Manual Reset)	50-1029
15	Expansion Tank	50-1030
16	Shut Off Air Bleeder	50-1031
17	Pressure Relief Valve	50-1032
18	Hopper Lid	50-1042
19	Top	50-1043
20	Cab Side Right	50-1044
21	Cab Side Left	50-1045
22	Louver Set Of 4	50-1046
23	Door Trim	50-1049
24	Ash Pan Cover	50-1050
25	Ash Pan	50-1051
26	Door Complete	50-1052
27	Door Handle	50-1053
28	Door Hinge Bracket	50-1054
29	Glass	50-1055
30	Tube Cleanout Gaskets	50-1056
31	Cleanout Cover Gaskets	50-1057
32	Water pressure & temperature gauge	50-1058
33	Control panel with decal	50-1059
34	Burn Pot Scraper Tool	50-1254
35	Burn Pot	50-1344
36	Burn Pot Liner	50-1345
37	Auger	50-1346
	Motor Kit - 220V	50-1347
38	Back Grill	50-1850

# PARTS DIAGRAM - COMPONENTS



EF Thermo 28 - Components  
April 2008

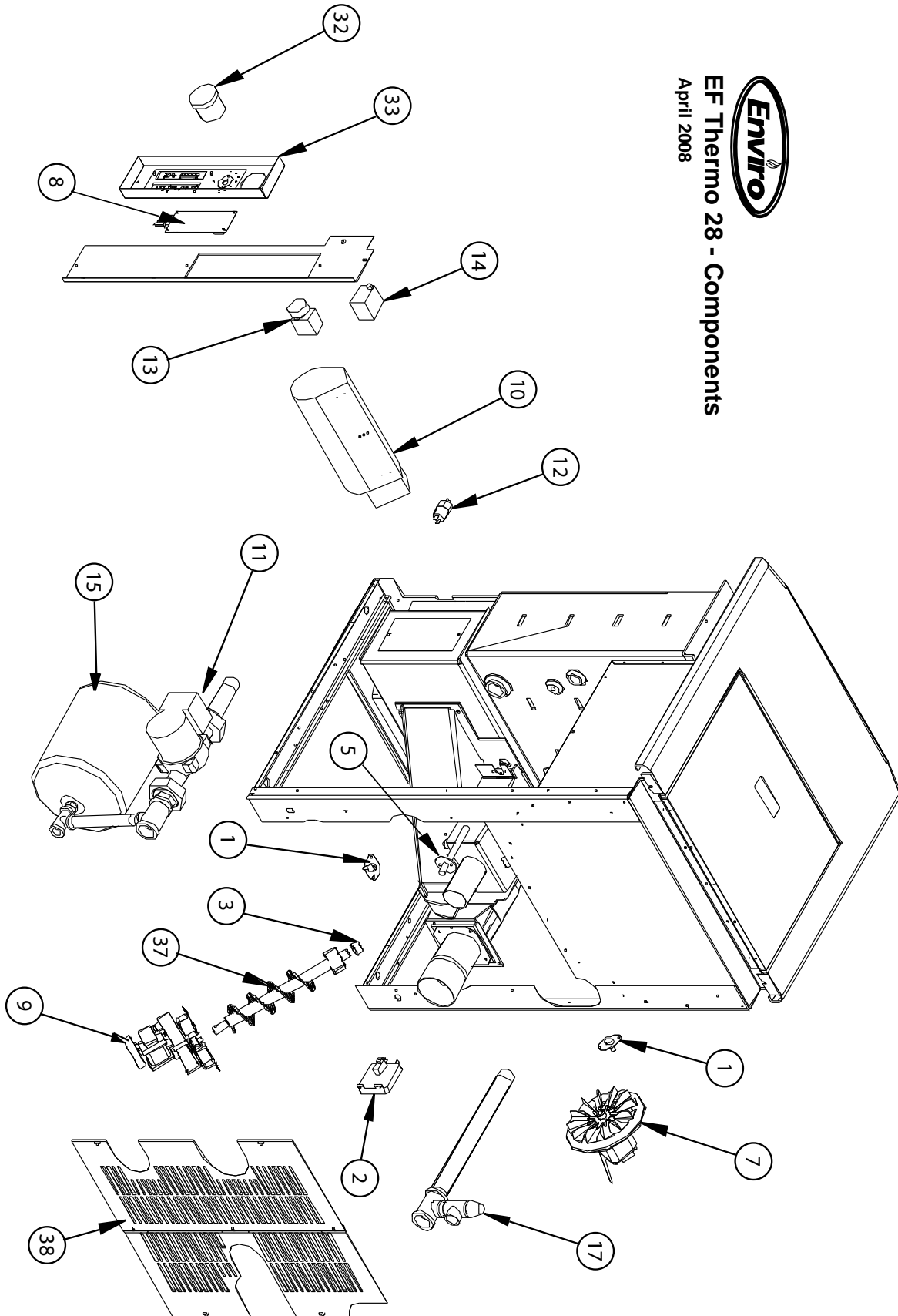



# PARTS DIAGRAM - BODY



EF Thermo 28 - Steel Components  
April 2008

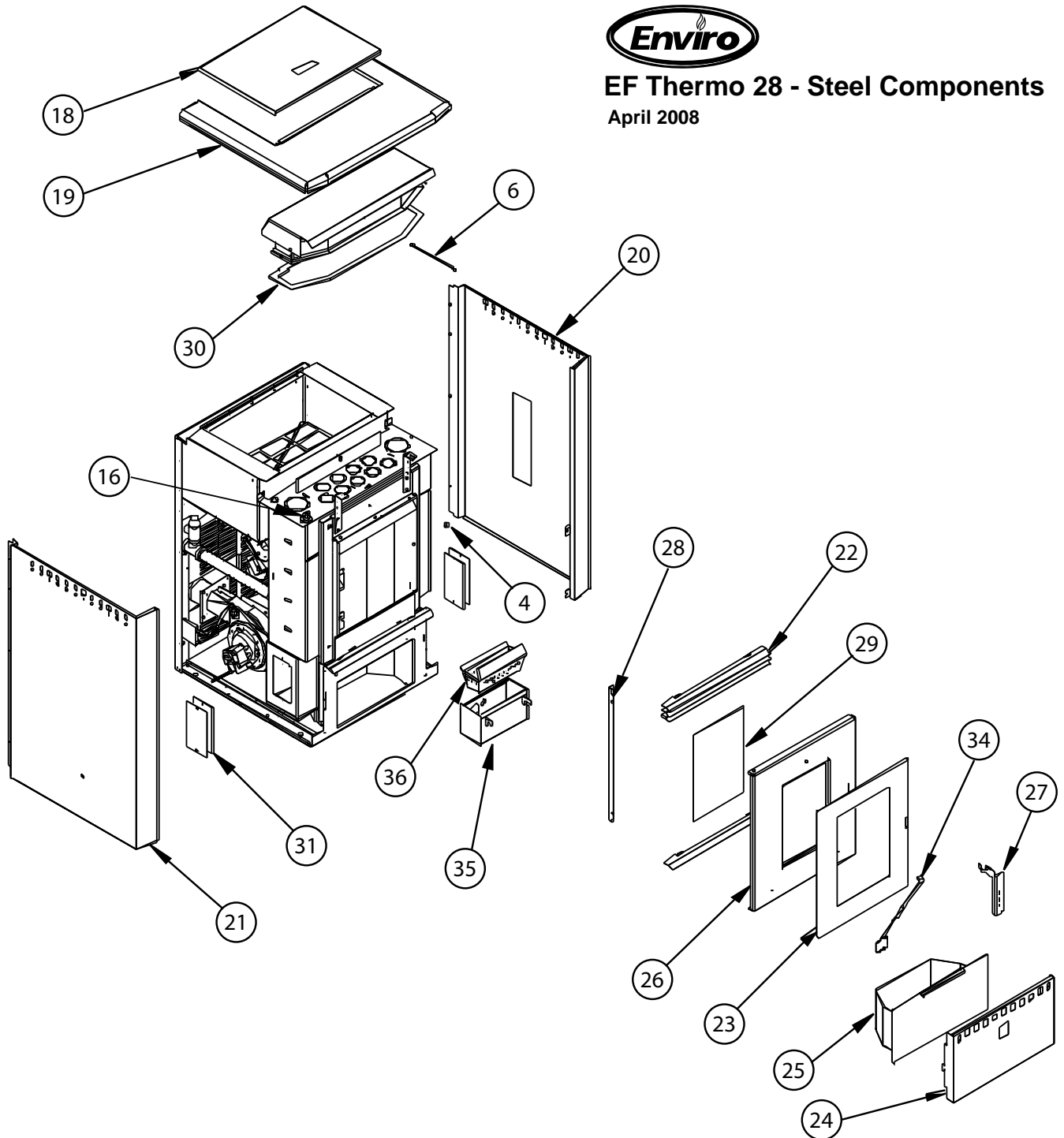

# INSTALLATION DATA SHEET

The following information must be recorded by the installer for warranty purposes and future reference.

NAME OF OWNER:  
\_\_\_\_\_  
  
ADDRESS:  
\_\_\_\_\_  
\_\_\_\_\_  
\_\_\_\_\_  
  
PHONE: \_\_\_\_\_

NAME OF DEALER:  
\_\_\_\_\_  
  
ADDRESS:  
\_\_\_\_\_  
\_\_\_\_\_  
\_\_\_\_\_  
  
PHONE: \_\_\_\_\_

MODEL: \_\_\_\_\_  
SERIAL NUMBER: \_\_\_\_\_  
DATE OF PURCHASE: \_\_\_\_\_ (dd/mm/yyyy)  
DATE OF INSTALLATION: \_\_\_\_\_ (dd/mm/yyyy)  
MAGNEHELIC AT INSTALL: \_\_\_\_\_  
INSTALLER'S SIGNATURE:  
\_\_\_\_\_

NAME OF INSTALLER:  
\_\_\_\_\_  
  
ADDRESS:  
\_\_\_\_\_  
\_\_\_\_\_  
\_\_\_\_\_  
  
PHONE: \_\_\_\_\_

**WARRANTY:** If you have any concerns with your unit please contact the dealer where you purchased the stove.

MANUFACTURED BY:  
SHERWOOD INDUSTRIES LTD.  
6782 OLDFIELD RD. SAANICHTON, BC, CANADA V8M 2A3  
www.enviro.com  
April 30, 2008  
C-1206