



SHERWOOD INDUSTRIES IS AN ENVIRONMENTALLY RESPONSIBLE COMPANY. THIS MANUAL IS PRINTED ON RECYCLED PAPER.

PLEASE KEEP THESE INSTRUCTIONS FOR FUTURE REFERENCE



PELLET STOVE **Empress**

Fireplace Insert

OWNER'S MANUAL

WARRANTY REGISTRATION
enviro.com/warranty





Contact your building or fire officials about restrictions and installation inspection requirements in your area.



PLEASE READ THIS ENTIRE MANUAL BEFORE INSTALLATION AND USE OF THIS PELLET BURNING ROOM HEATER. FAILURE TO FOLLOW THESE INSTRUCTIONS COULD RESULT IN PROPERTY DAMAGE, BODILY INJURY, OR EVEN DEATH.

Table of Contents

Introduction.....	3
Pellet Quality.....	3
Automatic Safety Features.....	3
Important Safety Data.....	4
Safety Warnings And Recommendations.....	4
Specifications.....	6
Dimensions.....	6
Rating Label Location.....	6
Rating Label.....	7
Operating Instructions.....	8
Control Board Functions.....	8
Operating Your Pellet Stove.....	8
Turning Your Pellet Stove Off:.....	9
Guidelines For Fine-Tuning For Fuel Quality.....	9
Slider/Damper Setting.....	10
Routine Cleaning and Maintenance.....	11
Warranty.....	14
Installation Data Sheet.....	15

 <p>NATIONAL FIREPLACE INSTITUTE NFI CERTIFIED www.nficertified.org</p>	<p>We recommend that our pellet hearth products be installed and serviced by professionals who are certified in the U.S. by the National Fireplace Institute® (NFI) as NFI Pellet Specialists or who are certified in Canada by Wood Energy Technical Training (WETT).</p>	 <p>Wood Energy Technical Training www.wettinc.ca</p>
---	--	--

Introduction

*** This manual is designed for the home owner in conjunction with the technical manual. ***

PELLET QUALITY:

Pellet quality is important, please read the following:

Your enviro pellet stove has been designed to burn wood pellets only. Do not use any other type of fuel, as this will void any warranties stated in this manual.

The performance of your pellet stove is greatly affected by the type and quality of wood pellets being burned. As the heat output of various quality wood pellets differs, so will the performance and heat output of the pellet stove.

CAUTION: It is important to select and use only pellets that are dry and free of dirt or any impurities such as high salt content. Dirty fuel will adversely affect the operation and performance of the unit and will void the warranty.

ASH: The ash content of the fuel and operation of your stove will directly determine the frequency of cleaning. The use of high ash fuels may result in the stove needing to be cleaned daily. A low ash fuel may allow longer intervals between cleaning.

CLINKERING: [clinkers are silica (sand) or other impurities in the fuel that will form a hard mass during the burning process]. This hard mass will block the air flow through the Burn Pot Liner and affect the performance of the stove. Any fuel, even approved types, may tend to clinker. Check the Burn-Pot Liner daily to ensure that the holes are not blocked with clinkers. If they become blocked, remove the liner (when the unit is cold) and clean/scrape the clinkers out. Clean the holes with a small pointed object if required. Refer to the section Routine Cleaning and Maintenance.

PELLET FEED RATES: Due to different fuel densities and sizes, pellet feed rates may vary. This may require an adjustment to the slider damper setting or to the auger feed trim setting on Low.

Since Sherwood Industries Ltd. has no control over the quality of pellets that you use, we assume no liability for your choice in wood pellets.

Store pellets at least 36" (1 m) away from the pellet stove.

AUTOMATIC SAFETY FEATURES:

Your pellet Stove has the following safety features:

- A) The stove will shut off when the fire goes out and the exhaust temperature drops below 120 °F (49°C).
- B) The stove has a high temperature safety switch. If the temperature on the hopper reaches 200 °F (93 °C) the auger will automatically stop and you will get a #2 flash code, and the stove will shut off when the exhaust temperature cools. If this happens call your local dealer to reset the 200 °F (93 °C) high limit switch. **FIND THE REASONS WHY THE UNIT OVERHEATED.**
- C) The unit is equipped with a vacuum switch to monitor the venting and the build up of ash in the burn pot; if either becomes blocked the vacuum switch will turn off the auger and the stove will shut off.

Introduction

IMPORTANT SAFETY DATA:

Please read this entire Owner's Manual before installing or operating your ENVIRO Pellet Stove. Failure to follow these instructions may result in property damage, bodily injury or even death. Contact your local building or fire official to obtain a permit and any information on installation restrictions and inspection requirements for your area.

To prevent the possibility of a fire, ensure that the appliance is properly installed by adhering to the installation instructions. An ENVIRO dealer will be happy to assist you in obtaining information with regards to your local building codes and installation restrictions.

The stove's exhaust system works with negative combustion chamber pressure and a slightly positive chimney pressure. It is very important to ensure that the exhaust system be sealed and airtight. The ash pan and viewing door must be locked securely for proper and safe operation of the pellet stove.

Do not burn with insufficient combustion air. A periodic check is recommended to ensure proper combustion air is admitted to the combustion chamber. Setting the proper combustion air is achieved by adjusting the slider damper located in the front of the unit under the ash pan.

Soot or creosote may accumulate when the stove is operated under incorrect conditions such as an extremely rich burn (black tipped, lazy orange flames).

If you have any questions with regard to your stove or the above-mentioned information, please feel free to contact your local dealer for further clarification and comments.

SAFETY WARNINGS AND RECOMMENDATIONS:

Caution: Do not connect to any air distribution duct system.

Do not burn garbage or flammable fluids such as gasoline, naphtha or engine oil.

Unit hot while in operation. Keep children, clothing and furniture away. Contact may cause skin burns.

FUEL: This pellet stove is designed and approved to only burn wood pellet fuel with up to 3% ash content. Dirty fuel will adversely affect the operation and performance of the unit and may void the warranty. Check with your dealer for fuel recommendations.

THE USE OF CORDWOOD IS PROHIBITED BY LAW.

SOOT: Operation of the stove with insufficient combustion air will result in the formation of soot which will collect on the glass, the heat exchanger, the exhaust vent system, and may stain the outside of the house. This is a dangerous situation and is inefficient. Frequently check your stove and adjust the slider/damper as needed to ensure proper combustion. **See: OPERATING INSTRUCTIONS - SLIDER / DAMPER SETTING.**

CLEANING: There will be some build up of fly ash and small amounts of soot in the exhaust. This will vary due to the ash content of the fuel used and the operation of the stove. It is advisable to inspect and clean the exhaust vent semi-annually or every two tons of pellets.

Introduction

ASHES: Disposed ashes should be placed in a metal container with a tight-fitting lid. The closed container of ashes should be on a non-combustible floor on the ground, well away from all combustible materials pending final disposal. The ashes should be retained in the closed container until all cinders have thoroughly cooled before disposing of them.

ELECTRICAL: The use of a surge protected power bar is recommended. The unit must be grounded. The grounded electrical cord should be connected to a standard 120 volts, 60 hertz electrical outlet and also must be accessible. If this power cord should become damaged, a replacement power cord must be purchased from the manufacturer or a qualified ENVIRO dealer. Be careful that the electrical cord is not trapped under the appliance and that it is clear of any hot surfaces or sharp edges. This unit's maximum power requirement is (4.1 Amps) 500 watts.

GLASS: Do not abuse the glass by striking or slamming the door. Do not attempt to operate the stove with broken glass. The stove uses ceramic glass. Replacement glass must be purchased from an ENVIRO dealer. Do not attempt to open the door and clean the glass while the unit is in operation or if glass is hot. To clean the glass, use a soft cotton cloth and mild window cleaner, gas or wood stove glass cleaner, or take a damp paper towel and dip into the fly ash. This is a very mild abrasive and will not damage the glass.

FLAMMABLE LIQUIDS: Never use gasoline, gasoline-type lantern fuel, kerosene, charcoal lighter fluid, or similar liquids to start or "freshen up" a fire in the heater. Keep all such liquids well away from the heater while it is in use.

SMOKE DETECTOR: Smoke detectors should be installed and maintained in the structure when installing and operating a pellet burning appliance.

OPERATION: The ash pan and door must be closed securely for proper and safe operation of the pellet stove. Also ensure all gaskets on the door are checked and replaced when necessary.

KEEP ASH PAN FREE OF RAW FUEL.

DO NOT PLACE UNBURNED OR NEW PELLETS IN ASH PAN. A fire in the ash pan may occur.

If you have any questions with regards to your stove or the above-mentioned information, please feel free to contact your local dealer for further clarification and comments.

SINCE SHERWOOD INDUSTRIES LTD. HAS NO CONTROL OVER THE INSTALLATION OF YOUR STOVE, SHERWOOD INDUSTRIES LTD. GRANTS NO WARRANTY IMPLIED OR STATED FOR THE INSTALLATION OR MAINTENANCE OF YOUR STOVE. THEREFORE, SHERWOOD INDUSTRIES LTD. ASSUMES NO RESPONSIBILITY FOR ANY CONSEQUENTIAL DAMAGE(S).

SAVE THIS INSTRUCTION MANUAL FOR FUTURE REFERENCE

Specifications

DIMENSIONS:

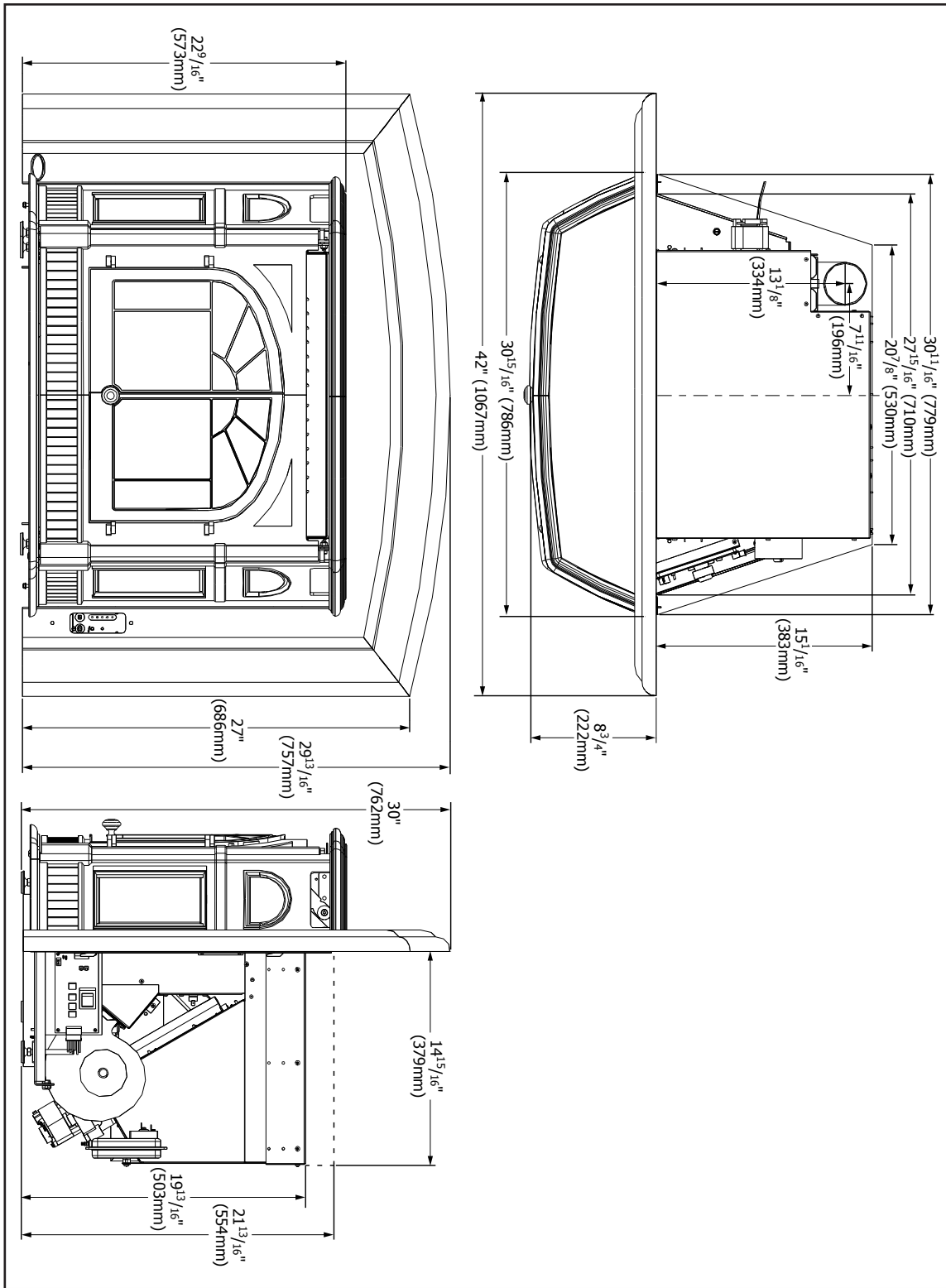

Figure 1: Dimensions of Empress Fireplace Insert.

RATING LABEL LOCATION:

The rating label is located on the hopper top behind the surround panel.

Specifications

RATING LABEL:

WH- Enviro Model / Modèle: **EMPRESS FPI** **MILAN**

Serial No. / No. De Série:

Listed Room Heater, Pelletized Fuel Type (Appareil de chauffage à granulés certifié)
 Suitable For Mobile Home Installation (Accepté pour l'installation dans une maison mobile, test)
 REPORT #307-4141-00 (February 2006)
 Tested to (Testée selon): ASTM 1509-04, US Environmental Protection Agency, certified to comply July 1, 1990,
 particulate emission standards. (États-Unis Environmental Protection Agency, a certifié pour conformer au
 juillet 1, 1990, les normes de particules d'émission.)

This pellet appliance has been tested and listed for use in manufactured homes in accordance with Oregon Administration
 Rules 814-23-900 through 814-23-909. Install and use only in accordance with the Manufacturer's installation and operating
 instructions. Contact local building or fire officials about restrictions and installation inspection in your area. Do not connect
 this unit to a chimney flue serving another appliance. See local building codes and manufacturer's instructions for precautions
 required for passing a chimney through a combustible wall or ceiling. Electrical rating: 120 volts, 60 Hz, 4.1 Amps. Route
 cord away from the heater.

Cet appareil a été testé et certifié pour utilisation dans les maisons mobiles en accord avec les Règles Administratives
 de l'Oregon 814-23-900 à 814-23-909. Installez et utilisez cet appareil seulement selon les instructions d'installation et
 d'opération du fabricant. Contactez les autorités locales de votre quartier concernant les restrictions et les inspections
 d'installation. Consultez les codes de bâtiment locaux et les instructions du fabricant pour les précautions à prendre
 lorsque une cheminée doit être installée à travers un mur ou un planché combustible. CLASSEMENT ÉLECTRIQUE :
 120 Volts, 60 Hz, 4.1 Amps. Placez le câble électrique loin de la cheminée.
 For Use With Only Pelletized Wood Fuels. Operate only with venting door and ash removal door closed. Only replace glass
 with ceramic glass. Components required for installation: a 3 inch (75 mm) or 4-inch (100 mm) listed PL vent, complete with
 components. Hearth must installations of listed single wall chimney liner may be used. Inspect and clean Exhaust Venting
 system frequently.
 Utilisation avec les combustibles sous forme de boîtes uniquement. Utilisez seulement lorsque les portes avant et la
 porte du réceptacle de cendre sont fermées. Si une ou des vitres de la vent doivent être remplacées, utilisez seulement du verre
 céramique. Les composants requis pour l'installation sont un évent PL certifié de 3in/75mm or 4in/100mm avec ses

DO NOT REMOVE THIS LABEL / NE RETIREZ PAS CETTE ÉTIQUETTE

INPUT Rating: 12,000 to 36,000 BTU/Hr. (3.5 to 10.5 kW)

LIGHTING INSTRUCTIONS: Press and release the on/off button. Once fire has started, set the heat output to the desired setting.
TO TURN THE UNIT OFF: Push the on/off button (Refer to owners manual for detailed instructions)

INSTRUCTIONS POUR L'ALLUMAGE: Presse et relâche le sur / de bouton. Une fois le feu a commencé, a règle le production de chaleur au montage désiré.
POUR ÉTEINDRE L'UNITÉ: Appuyer le sur / de bouton (Référer-vous au guide de l'utilisateur pour un mode d'emploi détaillé.)

MANUFACTURED BY: FERROQUE PAR.
 SHERWOOD INDUSTRIES LTD.
 VICTORIA, BC CANADA

Enviro

US

Intertek
 15911
 Certified for use in Canada & USA
 Certifié pour installation au
 Canada et aux États-Unis.

CAUTION: Hot while operating. Do not touch, severe burns may result. **Keep children, clothing, furniture, gasoline or other flammable vapors away.**
 See installation and operating instructions accompanying appliance. / Consultez le manuel avec les instructions d'installation et d'opération.



ATTENTION: Très chaud quand allumé. Ne touchez pas, les brûlures sévères peuvent résulter. **Tenez loin des enfants, des vêtements, des meubles, de l'essence ou d'autres fluides produisant des vapeurs inflammables.**
 Voir les instructions d'installation et d'opération de l'appareil. / Consultez le manuel avec les instructions d'installation et d'opération.

INSTALL AS A FIREPLACE INSERT STOVE MODEL (FPI) / A INSTALLER
 COMME UN MODÈLE SUR PIED DE POÈLE.
 Minimum clearances to combustible materials / Les dégagements minimums aux matériaux combustibles:

A	Sidelwall to center of unit (De la paroi au centre de l'unité)	24" (610 mm)
B	Sidelwall to surround panel (De la paroi à l'enrouleur le panneau)	3" (76 mm)
C	Bottom of unit to an unshielded 12" (305 mm) hearth (Le fond de l'unité à un marbreau de cheminée non blindé)	36" (914 mm)
D	Unit to top facing (protruding 3/4" (19 mm)) (De l'unité au sommet du parement)	0" (0 mm)
E	Unit to side facing (protruding 3/4" (19 mm)) (De l'unité au côté du parement)	0" (0 mm)
F	From door opening of unit to edge of floor protection (De la porte ouvrant au devant de protection de plancher)	6" (152 mm)
G	From side of unit to edge of floor protection (De l'ouverture de porte pour prendre parti de protection de plancher)	6" (152 mm)

Combustible floors must be protected by a non-combustible material.
 Le plancher combustible doit être protégé par un matériau incombustible.

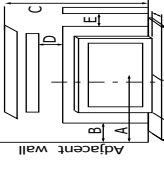

C-12054

DATE OF MANUFACTURE / DATE DE FABRICATION: J F M A M J J A S O N D 2012 2013 2014

Figure 2: Rating Label for Empress Fireplace Insert.

Operating Instructions

CONTROL BOARD FUNCTIONS:

1. THERMOSTAT SWITCH: Used to set the unit's controls to one of three mode settings; manual, high/low, or auto/off.

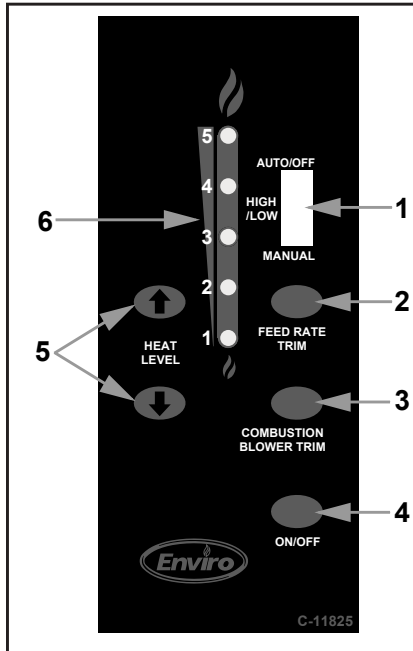

Figure 3: Circuit Board Control Panel Decal.

2. FEED RATE TRIM BUTTON: Used to change the feed rate trims in ¼ second increments for all feed settings. When this button is pressed, all the light will light up on the Heat Output Indicator except for the one that shows the current setting; the default setting is the number 4 light. To adjust the setting hold the Feed Rate Trim button down and press the Heat Level up or down buttons to adjust the setting.

3. COMBUSTION BLOWER TRIM BUTTON: Used to change the Combustion Blower trims in 5 volt increments for all feed settings until it reaches line voltage. When this button is pressed, all the light will light up on the Heat Output Indicator except for the one that shows the current setting; the default setting is the number 2 light. To adjust the setting hold the Combustion Blower Trim button down and press the Heat Level up or down buttons to adjust the setting.

4. ON/OFF BUTTON: Used to turn the unit ON and OFF.

5. HEAT LEVEL ADJUSTMENT BUTTONS: When pressed, will change the heat level setting of the unit up or down.

6. HEAT OUTPUT INDICATOR: Shows the present heat output setting.

OPERATING YOUR PELLET STOVE:

PRE-BURN INSTRUCTIONS: The burn pot liner holes must be clear and the liner installed properly against the ignitor tube for proper operation. Check the hopper for enough pellets to start the unit.

DO NOT OPERATE THE UNIT WITH THE DOOR OR ASH PAN OPEN.

Note: The thermostat mode can be changed during normal operation.

MANUAL MODE:

All control of circuit board function is adjusted at the circuit board.

To START: Press the ON / OFF button. The Heat Level Indicator will show the Heat Level that the stove will run at after start-up and can be adjusted but the change will not take affect until the start -up has finished.

If this is the first time the unit has been started or the unit has run out of fuel, the auger will need to be primed. This can be done by restarting the unit five (5) minutes into its start-up or by putting a small hand full of pellets into the burnpot.

To OPERATE: When a fire has been established after approximately 10 - 15 minutes the unit will switch from start up mode to run at the corresponding Heat Level setting. The convection blower (room air blower) will turn on. The speed of this blower is controlled by the setting of the heat level output indicator.

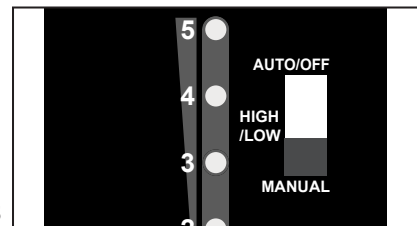

Figure 4: Thermostat Switch in MANUAL position.

Operating Instructions

HIGH/LOW MODE: (Requires a thermostat)

INITIAL START-UP: See manual mode above.

OPERATION: When the thermostat calls for heat (contacts are closed) the stove settings are adjustable as per Manual Mode. When the thermostat contacts open, the HEAT LEVEL and Fans will drop down to the LOW setting until the thermostat contacts close again. *The LOW heat setting can be adjusted for different fuel qualities (see "OPERATING INSTRUCTIONS - CONTROL BOARD FUNCTIONS"). The stove will come back to the previous HEAT LEVEL setting when the thermostat contacts close again.

AUTO/OFF MODE: (Requires a thermostat)

INITIAL START-UP: See manual mode above.

OPERATION: When the thermostat contacts close, the unit will light automatically. Once up to temperature, the stove operates the same as in MANUAL. When the thermostat contacts open, the stove's HEAT LEVEL and Fans will drop down to the LOW setting for 30 minutes. If the thermostat contacts close within the 30 minutes, the HEAT LEVEL will return to the previous MANUAL setting. If the thermostat contacts remain open the stove automatically begins its shutdown routine. The ON / OFF button can be pressed at any time the stove will immediately shut down. The stove will re-light when the thermostat contacts close again.

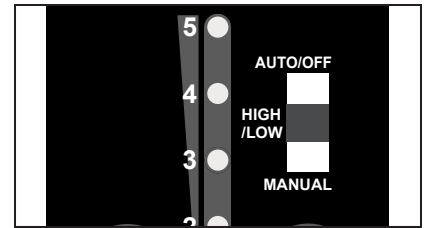

Figure 5: Thermostat Switch in HIGH/LOW position.

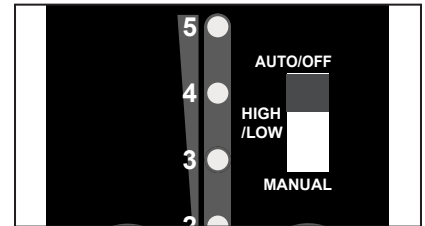

Figure 6: Thermostat Switch in AUTO/OFF position.

TURNING YOUR PELLETT STOVE OFF:

- MANUAL and HI / LOW mode: To turn the unit OFF, simply press the ON / OFF button. This will stop the feed of pellets. The blowers will continue to operate and cool the stove down. When cool enough, the stove will turn off.
- AUTO / OFF mode: To turn the unit OFF, turn the thermostat down or off. NOTE: The unit will run on low for three (3) minutes before it turns off.

**DO NOT unplug unit while Combustion fan is operating.
This may lead to smoke escaping from the stove.**

GUIDELINES FOR FINE-TUNING FOR FUEL QUALITY:

Due to fuel quality the slider damper and control board trims may need to be fine-tuned.

1. If the unit builds up on all settings, the slider damper rod should be pulled out in small increments to give the unit more air.
2. If the unit has excessive ash build-up in the liner on the lower feed settings, the Combustion Blower Trim should be increased one setting at a time until the problem improves (Factory Setting is #2).
3. If the fire is going out on low because the airflow is too great, the Combustion Blower Trim can be lowered to the #1 setting.
4. If the stove has excessive ash build-up in the liner on the higher settings the Feed Rate Trim should be trimmed down a setting at a time until the problem improves (Factory setting is #4).
5. If you need more heat and the fuel has long pellets, the majority are over 1" (2.5cm) in length, the Feed Rate Trim can be moved up to the #5 setting. NOTE: Only do this if the fuel burns without building up.

Operating Instructions

SLIDER/DAMPER SETTING:

This is used to regulate the airflow through the pellet stove.

THE SLIDER / DAMPER MUST BE SET AT TIME OF INSTALLATION.

A Qualified Service Technician or Installer must set the Slider Damper.

- If the fire should happen to go out and the heat output indicator has been set on the lowest setting, the Slider Damper should be moved to the left slightly, lessen the air flow into the firebox.
- If, after long periods of burning, the fire builds up and overflows the burn pot or there is a build up of clinkers, this would be a sign that the pellet quality is poor, this requires more primary air, the slider damper must be moved to the right to give the fire more air.

The easiest way to make sure that an efficient flame is achieved is to understand the characteristics of the fire.

- A tall, lazy flame with dark orange tips requires more air – Push Right
- A short, brisk flame, like a blowtorch, has too much air – Push Left
- If the flame is in the middle of these two characteristics with a bright yellow/orange, active flame with no black tips then the air is set for proper operation.

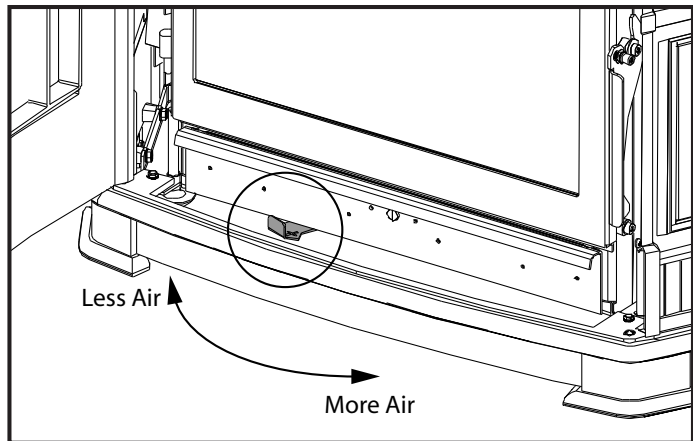

Figure 7: Slider / damper positions.



Figure 8: Efficient Flame.

The combustion exhaust blower is a variable speed blower controlled by the heat output setting. This blower will increase or decrease the blower speed as the heat output setting is turned up or down.

SPECIAL NOTES:

Pellet quality is a major factor in how the pellet stove will operate. If the pellets have a high moisture content or ash content the fire will be less efficient and has a higher possibility of the fire building up and creating clinkers (hard ash build-up). If this happens, move the Slider / Damper to the right slightly to increase the air flow to the fire.

Routine Cleaning and Maintenance

The following list of components should be inspected and maintained routinely to ensure that the appliance is operating at its optimum and giving you excellent heat value:

<u>2-3 Days / Weekly</u>	<u>Semi-annually or 2 Tons of Fuel</u>
Burn Pot and Liner	Fresh Air Intake
Door Latch	Exhaust Passages
Door Glass	Exhaust Vent
Ash pan and Door gaskets	Blower Mechanisms
Ash Pan	Behind firebox liners
Heat exchanger	All Hinges
Inside Firebox	Post Season Clean-up

TOOLS REQUIRED TO CLEAN UNIT

- Torx T-20 Screwdriver
- Brush
- Soft Cloth
- 5/16" Wrench or Socket
- Vacuum with fine filter bag

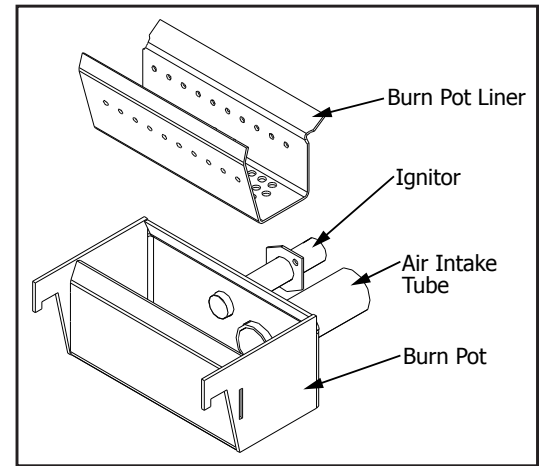

Figure 9: Burn pot assembly.

BURN POT AND LINER (2-3 days)

Cleaning of the burn pot and liner must only be done when stove is cold. To remove the burn pot and burn pot liner, open the door located on the right-hand side of the stove. Swing the door open. Lift the liner from the burn pot. Lift the burn pot from the firebox by gently lifting up the front of the burn pot, then sliding the assembly from the air intake tube and the ignitor cartridge.

This is the 'pot' where the pellets are burned. Every two to three days (when the unit is cold), remove the burn-pot liner from the stove and inspected it to ensure proper air flow through the liner. **Failure to keep the liner clean may cause a build up of fuel past the burn pot liner and up the drop tube. This will cause the auger to jam and may result in pellets burning in the drop tube and hopper.** Using a metal scrapper, remove material that has accumulated or is clogging the liner's holes. Then dispose of the scrapped ashes from the liner and from inside the burn-pot. Place the burn-pot back into the stove, making sure that the pipes are properly inserted into the burn pot. Place the liner back into the burn-pot, making sure that the ignitor hole in the liner is aligned with the ignitor tube. Pushing the liner up against the ignitor tube.

If, after long periods of burning, the fire continually builds up and overflows the burn pot or there is a build up of clinkers, this is an indication that the pellet fuel quality is poor or the stove may need cleaning. Check the stove for ash build up (clean if required) and adjust the slider / damper to produce the proper clean combustion.

DOOR LATCH (2-3 days)

Check the door latch every time the door is opened or closed to ensure proper engagement.

DOOR GLASS CLEANING (When needed)

Cleaning of the glass must only be done when stove is cold. Open the door by lifting the handle. The glass can be cleaned by wiping down the outside and inside of the glass with a dry soft cloth.

If the glass has build up that can not be removed with only the cloth, clean the glass using paper towel and a glass cleaner, a special glass cleaner can be purchased through most dealers. If a glass cleaner is not available, use a damp paper towel dipped in fly ash to clean the glass. After the glass has been cleaned use the dry soft cloth to wiping down the outside and inside of the glass.

Routine Cleaning and Maintenance

ASH PAN AND DOOR GASKETS (weekly)

After extended use the gasketing may come loose. To repair this, glue the gasketing on using high-temperature fiberglass gasket glue available from your local ENVIRO dealer. This is important to maintain an airtight assembly.

ASH PAN (2-3 days)

The ash pan is located under the door. To remove the ash pan, simply turn the latch with a large standard blade screwdriver and pull out towards the front. Dump the ashes into a metal container stored away from combustibles. Vacuum the ash pan and inside the firebox. **CAUTION: BECAUSE THE FLY ASH IS VERY FINE, THE USE OF A FINE FILTER VACUUM BAG WILL BE REQUIRED TO PREVENT ASH FROM BEING BLOWN BACK INTO THE ROOM.** Please pay special attention that there are no hot ashes in the firebox or there could be a possibility of a fire hazard inside the vacuum cleaner. Place all hot ashes into a non-combustible container.

Monitor the ash level every week. Remember that different pellet fuels will have different ash contents. Ash content is a good indication of fuel efficiency and quality. Refer to "INTRODUCTION - SAFETY WARNINGS AND RECOMMENDATIONS" for disposal of ashes. **It is important to latch the ash pan tightly when re-installing it.**

DO NOT PLACE UNBURNED OR RAW PELLET FUEL IN ASH PAN.

HEAT EXCHANGER (weekly)

Clean away any fly ash that may have collected on the heat exchanger by opening the door and brushing off the fins on the inside of the firebox. As different types of pellets produce different amounts of ash, cleaning of the fins should be done on a regular basis to enable the unit to run efficiently.

EXHAUST PASSAGES (season)

Removal of the firebox backing for bi-annual cleaning (refer to Figure 10):

- Open the door by lifting the handle.
- Remove the burn pot and burn pot liner.
- **Lubricate all screws with penetrating oil.**
- Remove the two (2) screws that hold each brick liner retainer in place. Remove side brick liners by sliding them forward then out.
- Pull the center panel out.
- Vacuum and clean thoroughly.

Installation of firebox backing:

- Insert center panel with backing.
- Place the two (2) side panels back into the firebox and reinstall the two (2) retainers using two (2) screws on each side.
- Replace the burn pot and burn pot liner
- Close the glass door and secure.

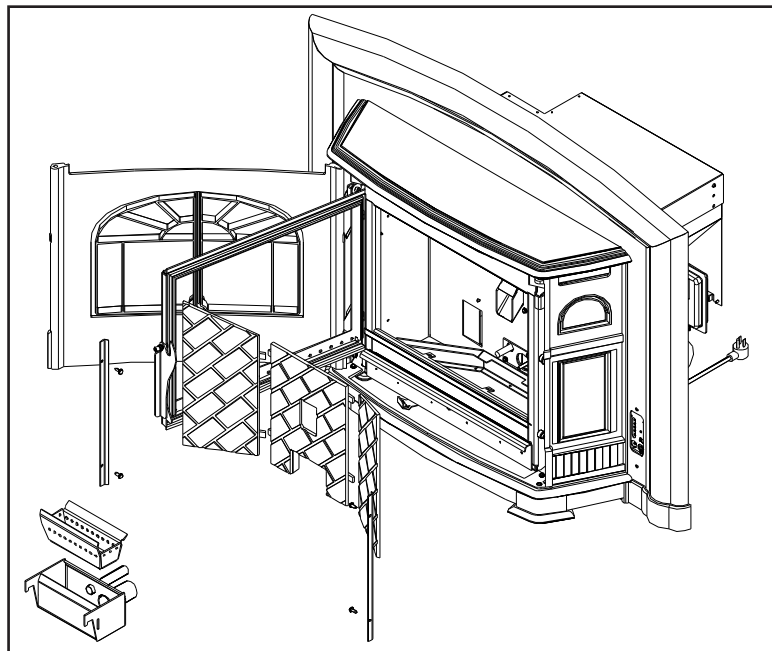

Figure 10: Firebox Components Removal.

Routine Cleaning and Maintenance

FRESH AIR INTAKE (season)

Inspect periodically to be sure that it is not clogged with any foreign materials.

EXHAUST VENT (season)

This vent should be cleaned every year or after two (2) tons of pellets. We recommend contacting your dealer for professional cleaning. To clean the vent pipe, run a chimney cleaning brush through the pipe. Open the bottom of the "T" to dump the ash, then vacuum as much of the ash out of the vent pipe as possible.

BLOWER MECHANISMS (season)

Unplug the stove and pull out the unit to access the two blowers. Vacuum all dust from motors and lubricate the convection motor. Check gaskets and replace if needed.

ALL HINGES (season)

Check all the hinges on the unit to ensure proper movement.

POST SEASON CLEAN-UP

Once you are finished using the pellet appliance for the season, run the unit out of fuel and unplug the stove for added electrical protection. It is very important that the stove be cleaned and serviced as stated above.

CLEANING SURFACES

Enamel finishes and painted surfaces can be wiped down with a soft damp cloth. The paint on the firebox panels may discolour or peel. This is due to extreme conditions applied to the paint and is in no way covered by warranty.

FIREBOX PANEL

All surfaces should be brushed off periodically.

REPLACING DOOR GLASS

It is recommended that your ENVIRO dealer replace the glass if broken.

The door glass is made of high temperature PYRO CERAMIC 5 mm thick. The panel is 18.5 x 13.5 inches (470 mm x 343 mm) and must be replaced with (PART # 50-1400). Substitute materials will not be permitted.



Warranty for Enviro Pellet Products

Sherwood Industries Ltd. ("Sherwood") hereby warrants, subject to the terms and conditions herein set forth, this product against defects in material and workmanship during the specified warranty period starting from the date of original purchase at retail. In the event of a defect of material or workmanship during the specified warranty period, Sherwood reserves the right to make repairs or to assess the replacement of a defective product at Sherwood's factory. The shipping costs are to be paid by the consumer. All warranties by Sherwood are set forth herein and no claim shall be made against Sherwood on any oral warranty or representation.

Conditions

- A completed warranty registration must be submitted to Sherwood within 90 days of original purchase via the online warranty registration page or via the mail-in warranty registration card provided. Have the installer fill in the installation data sheet in the back of the manual for warranty and future reference.
- This warranty applies only to the original owner in the original location from date of install.
- The unit must have been properly installed by a qualified technician or installer, and must meet all local and national building code requirements.
- The warranty does not cover removal and re-installation costs.
- Sherwood Industries Ltd. reserves the right to make changes without notice.
- Sherwood Industries Ltd. and its employees or representatives will not assume any damages, either directly or indirectly caused by improper usage, operation, installation, servicing or maintenance of this appliance.
- A proof of original purchase must be provided by you or the dealer including serial number.

Exclusions

An expanded list of exclusions is available at www.enviro.com/help/warranty.html

This warranty does not cover:

- Damage as a result of improper usage or abuse.
- Damage caused from over-firing due to incorrect setup or tampering.
- Damage caused by incorrect installation.

To the Dealer

- Provide name, address and telephone number of purchaser and date of purchase.
- Provide date of purchase. Name of installer and dealer. Serial number of the appliance. Nature of complaint, defects or malfunction, description and part # of any parts replaced.
- Pictures or return of damaged or defective product may be required.

To the Distributor

- Sign and verify that work and information are correct.

Sherwood Industries Ltd.

6782 Oldfield Road, Victoria, BC . Canada V8M 2A3
 Online warranty registration: www.enviro.com/warranty/

Category	One Year	Two Year	Limited Lifetime (7yr)
Parts ¹ (unit serial number required)		✓	
Firebox Brick Panels (Cast)		✓	
Firebox			✓
Heat Exchanger			✓
Burn Pot			✓
Burn Pot Liner		✓	
Firebox Liner Panels w/Insulation			✓
Ceramic Glass ²	✓		
Pedestal / Legs (excluding finish)			✓
Surround Panels (excluding finish)			✓
Exterior Panels (excluding finish)			Up to 5 years
Electrical Components		✓	
Steel Brick Liner (Metal)	✓		
Exterior Surface Finishing ³	✓		
Labour	✓		

¹ Whereas warranty has expired, replacement parts will be warrantied for 90 days from part purchase date. Labour not included. Unit serial number required.

² Glass is covered for thermal breakage. Photos of box, inside of door, and unit serial # must be supplied for breakage due to shipping.

³ Exterior Surface finishing covers Plating, Enamel or Paint and excludes colour changes, chipping, and fingerprints.

Gaskets not covered by Warranty.

Travel costs not included.

Cast Agitator: 1 year for pellet. Not covered when burning alternative fuels. (Cast agitators are a consumable item)

Installation Data Sheet

The following information must be recorded by the installer for warranty purposes and future reference.

NAME OF OWNER: _____
ADDRESS: _____ _____ _____
PHONE: _____

NAME OF DEALER: _____
ADDRESS: _____ _____ _____
PHONE: _____

MODEL: _____
SERIAL NUMBER: _____
DATE OF PURCHASE: _____ (dd/mm/yyyy)
DATE OF INSTALLATION: _____ (dd/mm/yyyy)
MAGNEHELIC AT INSTALL: _____
INSTALLER'S SIGNATURE: _____

NAME OF INSTALLER: _____
ADDRESS: _____ _____ _____
PHONE: _____

MANUFACTURED BY:
SHERWOOD INDUSTRIES LTD.
6782 OLDFIELD RD. SAANICHTON, BC, CANADA V8M 2A3
www.enviro.com
March 6, 2013
C-13842