



SHERWOOD INDUSTRIES IS AN ENVIRONMENTALLY RESPONSIBLE COMPANY
THIS MANUAL IS PRINTED ON RECYCLED PAPER



EG 28 Direct Vent

By SHERWOOD INDUSTRIES

OWNERS MANUAL



WHAT TO DO IF YOU SMELL GAS

- Open windows
- Do not try to light any appliance.
- Do not touch any electrical switch; do not use any phone in your building.
- Immediately call your gas supplier from a neighbor's phone. Follow the gas supplier's instructions.
- If you cannot reach your gas supplier, call the fire dept.

WARNING

If the information in this manual is not followed exactly, a fire or explosion may result causing property damage, personal injury or loss of life
installation and service must be performed by a qualified installer, service agency or the gas supplier.

FOR YOUR SAFETY

Do not store or use gasoline or other Flammable vapors and liquids in the vicinity of this or any other appliance.

Massachusetts's installations (**WARNING**): This product must be installed by a licensed plumber or gas fitter when installed within the Commonwealth of Massachusetts. Other Massachusetts requirements: Flexible connector must not be longer than 36", shutoff valve must be a "T" handle gas cock, only direct vent sealed combustion products are approved for bedroom/bathrooms, fireplace dampers must be removed or welded in the open position prior to the installation of a fireplace insert or gas log.

SAFETY PRECAUTIONS

FOR SAFE INSTALLATION AND OPERATION OF YOUR "ENVIRO" STOVE, PLEASE, CAREFULLY READ THE FOLLOWING INFORMATION:

GENERAL

- Installation and repair should be done by a qualified service person. The appliance should be inspected before use and at least annually by a qualified service person. More frequent cleaning may be required due to excessive lint from carpeting, bedding material, etc. It is imperative that control compartments, burners and circulating air passageways of the appliance be kept clean.
- Due to high temperatures the appliance should be located out of high traffic areas and away from furniture and draperies. Children and adults should be alerted to hazards of high surface temperatures and should stay away to avoid burns or clothing ignition.
- Young children should be carefully supervised when they are in the same room as the appliance.
- Clothing or other flammable material should not be placed on or near the appliance.

- All "ENVIRO" gas-fired appliances must be installed in accordance with these instructions. Carefully read all the instructions in this manual first. Consult the building authority having jurisdiction to determine the need for a permit prior to commencing the installation.

- **NOTE** Failure to follow these instructions could cause a malfunction of the fireplace, which could result in death, serious bodily injury, and/or property damage.
- Failure to follow these instructions may also void your fire insurance and/or warranty.

FOR YOUR SAFETY:

- A qualified installer, service agency or the gas supplier, should perform the installation or service.
- Installation must conform to local codes or, in the absence of local codes with the current CAN/CGA-B149 installation code in Canada or the current National Fuel Gas Code ANSI Z223.1 in the USA.

- To prevent injuries do not allow anyone who is unfamiliar with the operation to use the stove.
- **Always keep the appliance area clear and free of combustible materials, gasoline and other flammable vapors and liquids.**
- These appliances should not be used as a drying rack for clothing or for hanging Christmas stockings or decorations.
- Due to the paint curing on the stove a faint odor and slight smoking will likely be noticed when the stove is first used. Open a window until the slight smoking stops. Always connect this gas stove to a chimney and vent to the outside of the building envelope. Never vent to another room or inside a building. Make sure you use the vent pipe that is specified. Make sure that the vent is properly sized and is of adequate height to provide the proper draft. Inspect the venting system annually for blockage and any signs of deterioration.

WARNING: Do not operate with cracked or broken glass. Under no circumstances should this appliance be modified. Parts that have to be removed for servicing must be replaced prior to operating this appliance. Only parts supplied by Enviro should be used in this appliance and replacement should only be performed by a licensed or qualified service person.

- Never use solid fuels such as wood, paper, cardboard, coal, or any other flammable liquids, in this appliance.
- Do not use this heater if any part has been under water. Immediately call a qualified service technician to inspect the heater and to replace any part of the control system and any gas control, which has been under water.
- Do not abuse glass by striking or slamming door shut.

TABLE OF CONTENTS

| | |
|--------------------------------------|------------|
| Safety Precautions | 2 |
| Code Approvals | 3 |
| Deciding where to locate your stove | 4 |
| Planning your installation (Venting) | 5-13 |
| Installation of Log Sets and Embers | 14 |
| Operating Instructions | 15 |
| Maintenance and Technical | 16 |
| Trouble Shooting | 17 |
| Gas Line Connection | 18 |
| Electrical | 19 |
| Parts and Accessories | 20 |
| Fuel Conversion | 21 |
| Warranty | 22 |
| Parts List | 23 |
| Exploded Views | 24-25 |
| Installation Data Sheet | 26 |
| Mobile Home Information | 3,13,19,21 |

CODE APPROVALS

- This Direct Vent appliance draws all of its combustion air from outside of the dwelling through specially designed vent pipe.
These appliances have been tested by INTERTEK TESTING SERVICES (**WH**) and found to comply with the established standards for a DIRECT VENT GAS FIREPLACE in CANADA and the USA as follows:

| |
|---|
| <p>LISTED GAS FIRED GRAVITY DIRECT VENT WALL FURNACE (EG 28 DV. Nat. & LPG.) TESTED TO: ANSI Z21.88-1998 CSA 2.33-M98 VENTED GAS FIREPLACE HEATER.UL307B-1995 GAS BURNING HEATING APPLIANCES FOR MANUFACTURED HOMES. CGA 2.17-M91 GAS FIRED APPLIANCES FOR USE AT HIGH ALTITUDE</p> |
|---|

SPECS:

ENVIRO EG 28 DIRECT VENT UNITS;

- Have all been certified for use with either natural or propane gases (see control panel and rating label).
- Are not for use with solid fuels.
- Must not be connected to a chimney flue serving a separate solid-fuel burning appliance.
- Are approved for bedroom or bedsitting room.
 - (**IN CANADA:** must be installed with a listed wall thermostat)
 - (**IN USA:** see current ANSI Z223.1 for installation instructions)
- Must be installed in accordance with local codes if any. If none exist use current installation code CAN/CGA-B149 in Canada or ANSI Z223.1 / NFPA 54 in the USA.
- Must be properly connected to an approved venting system.
- Manufactured (mobile) home installation must be in accordance with the Manufactured Home Construction and Safety Standard, UL307B, Title 24 CFR, Part 3280 and/or The Standard for Manufactured Home Installations, ANSI A225.1/NFPA 501A. The unit must be bolted to the floor of the mobile home and must be electrically grounded to the steel chassis.
- Are approved for installation on combustible materials.
- Are not approved for closet or recessed installations.

ASSEMBLY INSTRUCTIONS

PREPARATION FOR INSTALLATION

- Remove the packaging from the appliance, and check to make sure there is no damage. If damage is found, please report it to both the carrier and your dealer as soon as possible.
- Before beginning, carefully check the glass door and the log set.

DECIDING WHERE TO LOCATE YOUR STOVE

DIMENSIONS:

Front Width: 22" (56 cm)
Rear Width: 22" (56 cm)
Height: 27-1/2" (70 cm)*
Depth: 19" (48 cm)
(*Not including vent coupling)

Shipping Weight: 210lbs (95 kg)

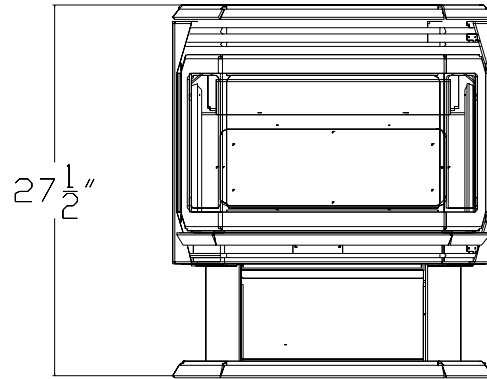

FIG. 1

CLEARANCES:

| | |
|-----------------------------|--------------|
| A. Side wall to stove | 10" (25 cm) |
| B. Rear wall to stove | 4" (10 cm) |
| C. Combustible to stove Top | 22" (56 cm) |
| D. Floor to stove | 0" (0 cm) |
| E. Corner clearance | 2" (5 cm) |
| F. Alcove depth | 48" (122 cm) |

Maintain sufficient clearances for service and maintenance.

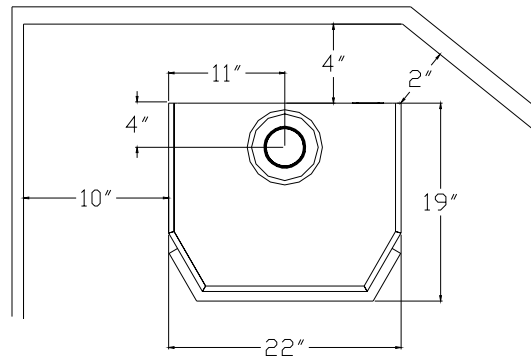
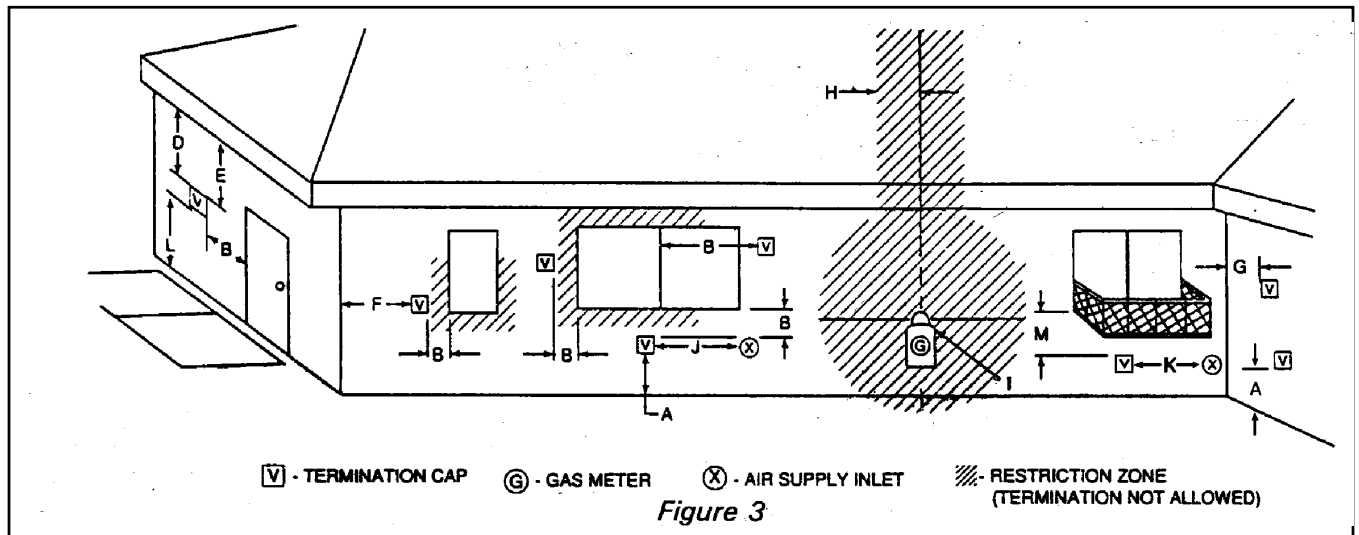

FIG. 2

- The stove should be located out of traffic and away from furniture and draperies.
- The stove should have sufficient access for its safe operation and maintenance.
- Locate a position where the flue system of the stove can be properly installed without damaging the integrity of the building. E.g. cutting a wall or ceiling joist.
- The stove can be installed on any standard flooring materials i.e. Wood, carpet or linoleum.
- Check stove and flue system clearance requirements.
- Locate the stove where it can be accessed by a gas supply line.
- Locate the stove in a large and open room that is centrally located in the house. This will optimize heat circulation and comfort.
- As the stove is equipped with a convection fan, ensure that an electrical outlet is within 6ft. (1.8m) of the stove.
- These stoves can be installed in bedrooms.
 - (IN CANADA: must be installed with a listed wall thermostat)
 - (IN USA: see current ANSI Z223.1 for installation instructions.)
- The flow of combustion and ventilation air must not be obstructed.

VENT TERMINAL CLEARANCES



- A= Clearance above grade, verandah, porch, deck, or balcony [*12 inches (30 cm) minimum]
- B= Clearance to window or door that may be opened [*12 inches (30 cm) minimum]
- C= Clearance to permanently closed window [minimum 12 inches (30 cm) recommended to prevent condensation on window]
- D= Vertical clearance to ventilated soffit located above the terminal within a horizontal distance of 2 feet (60 cm) from the center-line of the terminal (24 inches (60 cm) minimum)
- E= Clearance to unventilated soffit [18 inches (45 cm) minimum]
- F= Clearance to outside corner [12 inches minimum]
- G= Clearance to inside corner [12 inches minimum]

- H= *Not to be installed above a meter/regulator assembly within 3 feet (90 cm) horizontally from the center-line of the regulator
- I= Clearance to service regulator vent outlet [*6 feet (1.8m) minimum]
- J= Clearance to non-mechanical air supply inlet to building or the combustion air inlet to any other appliance [12 inches (30 cm) minimum]
- K= Clearance to a mechanical air supply inlet [*6 feet (1.8m) minimum]
- L=*** Clearance above paved side-walk or paved driveway located on public property [*7 feet (2.1m) minimum]
- M= Clearance under verandah, porch, deck, or balcony [*24 inches (60 cm) minimum **]

*** A vent shall not terminate directly above a sidewalk or paved driveway, which is located between two single-family dwellings and serves both dwelling

** Only permitted if verandah, porch, deck, or balcony is fully open on a minimum of 2 sides beneath the floor
As specified in CGA B149 Installation Codes (1991) Note: Local Codes or Regulation

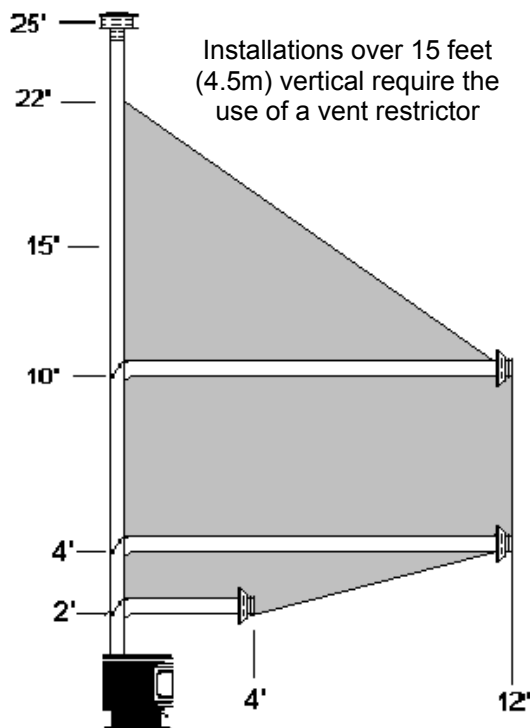

WHEN VENTING THIS APPLIANCE YOU MUST STAY WITHIN THE SHADED AREA (see venting chart provided) FOR ALL VENTING APPLICATIONS.

VENT RESTRICTOR RING: A vent restrictor ring is supplied with each direct vent fireplace. This restrictor ring is to be installed when the vertical chimney installation is over 15' (4.57 M). Before the chimney is placed onto the stove, place this vent restrictor ring into the 4" (10.16 CM) flue pipe (as shown), once the vent restrictor ring has been installed, the vertical sections of chimney can be installed.

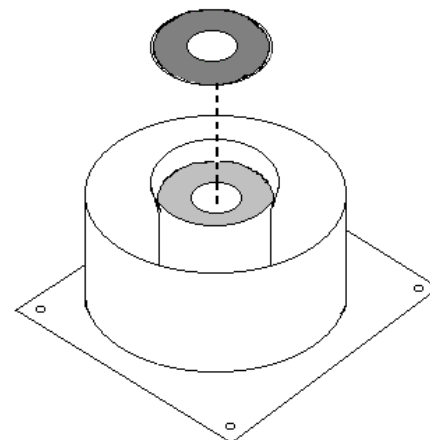

These models have been tested and certified for use with SIMPSON DURAVENT DIRECT VENT TYPE "GS" PIPE FOR GAS STOVES. SECURITY VENTING SYSTEMS (SECURE VENT) Kits are available for vertical venting or horizontal venting. It is recommended that a bead of RTV High Temperature Silicone be applied to each outer vent joint and milpac to each inner joint before installation.

This model has also been tested for horizontal venting installations when using SHERWOOD INDUSTRIES LTD. horizontal venting kit PART # EG 40-500

SHERWOOD INDUSTRIES LTD PARTS:

| | | | |
|---|--|----|-----------------------------------|
| 1 | Horizontal direct vent termination cap | 4 | Spring spacers |
| 1 | Flue collar adapter 5" tall (4 T20 Torx) | 3 | Decorative brass rings |
| 1 | Wall thimble | 1 | 4oz tube RTV silicone |
| 1 | Inside finish trim collar | 1 | 4oz can charcoal gray spray paint |
| 1 | 5' length of 4" double walled flex pipe | 20 | 9/16" tech screw |
| 2 | 24" sections 6 5/8" straight pipe | 8 | 1 1/2" wood screws |
| 1 | 6 5/8" 90° elbow | 1 | Vinyl siding deflector |

A MINIMUM VERTICAL LENGTH OF 24" (60cm) TO THE FIRST 90 DEGREES ELBOW IS REQUIRED. WITH THIS MINIMUM VERTICAL RISE, HORIZONTAL RUNS OF FROM ONE TO FOUR FEET ARE PERMITTED TO REACH THE OUTSIDE VENT TERMINATION.

BEFORE BEGINNING THE INSTALLATION TAKE CARE TO ENSURE AN APPROPRIATE OUTSIDE LOCATION FOR THE VENT TERMINATION CAN BE ACCOMMODATED. **FOLLOW THE VENT LENGTH DIAGRAM PRECISELY.**

VENTING TERMINALS CANNOT BE RECESSED INTO A WALL OR SIDING.

If extra elbows are being used, overall allowable length will be reduced by 3 ft. per additional elbow

Simpson Duravent Parts

| Number | Description | Number | Description |
|---------|---------------------------------------|--------|------------------------------------|
| 907B | 9" Pipe Length, Black | 943S | Flashing, 7/12 to 12/12 Roof Pitch |
| 906 (B) | 12" Pipe Length, (Black) | 953 | Storm Collar |
| 904 (B) | 24" Pipe Length, (Black) | 963 | Ceiling Firestop |
| 903 (B) | 36" Pipe Length, (Black) | 988 | Wall Strap |
| 902 (B) | 48" Pipe Length, (Black) | 984 | Horizontal Square Termination |
| 911 (B) | 11" to 14-5/8" Pipe Adjustable, Black | 985 | High Wind Horizontal Termination |
| 945 (B) | 45° Elbow, (Black) | 980 | Vertical Termination |
| 990 (B) | 90° Elbow, (Black) | 991 | High Wind Vertical Termination |
| 940 | Round Support / Wall Thimble Cover | 950 | Vinyl Siding Standoff |
| 941 | Cathedral Ceiling Support Box | 942 | Wall Thimble |
| 943 | Flashing, 0/12 to 6/12 Roof Pitch | 971 | Horizontal Termination Kit A |

Add suffix (B) for optional black parts as listed.

PLANNING YOUR INSTALLATION

There are two basic types of Direct Vent System installations. The two types of installations are:

Vertical Termination

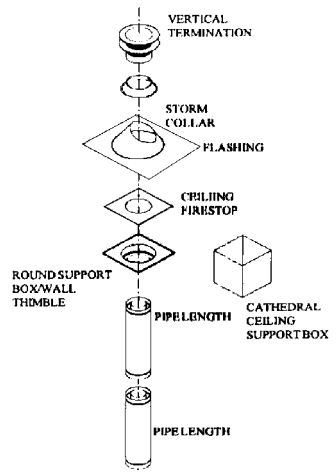

Horizontal Termination

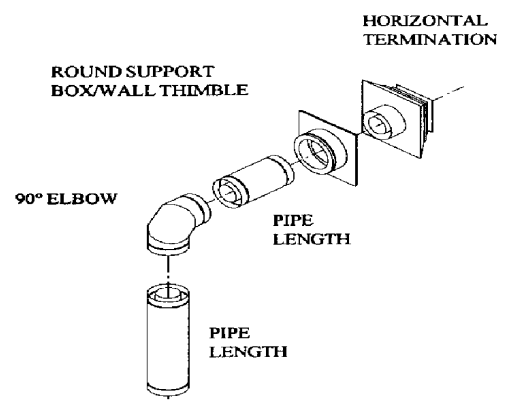

When planning your installation, it will be necessary to select the proper length of vent pipe for your particular requirements. It is important to note when passing through a wall, the maximum allowable wall thickness is 10-inches (25.4cm), 1 ½ inches clearance to combustibles must be maintained. Select the amount of vertical rise desired for “vertical-to-horizontal” type installations. To determine the length of vent pipe required for vertical installations, measure the distance from the appliance flue outlet to the ceiling, the ceiling thickness, the vertical rise through the attic or second story, and allow for sufficient vent height above the roofline. For two story applications, a firestop is required at each floor level. If an offset is needed in the attic, additional pipe and elbows will be required. To connect the venting system to the appliance flue outlet, a twist-lock adapter is built into the appliance at the factory.

HORIZONTAL INSTALLATION

STEP 1. Set the appliance in the desired location. Check to determine if wall studs or roof rafters are in the way when the venting system is attached. If this is the case, you may want to adjust the location of the appliance.

STEP 2. Direct vent pipe and fittings are designed with special twist-lock connections. Assemble the desired combination of black pipe and elbows to the appliance adapter with pipe seams oriented towards the wall or floor, as much out of view as possible.

Place a bead of Mil-Pac on the outer edge of the inner exhaust pipe (non-flared end). Place a bead of high temperature silicone on the male edge of the outer pipe. Push the pipe sections completely together, then twist-lock one section clockwise approximately one-quarter turn, until the two sections are fully locked. The female locking lugs will not be visible from the outside, on black pipe. They may be located by examining the inside of the female ends as shown in FIG-10.

NOTE:

(1) Twist-lock procedure: four indentations, located on the female end of the pipes and fittings, are designed to slide straight onto the male ends of adjacent pipes and fittings, by orienting the four pipe indentations so they match and slide into the four entry slots on the male end.

(2) Horizontal runs of vent pipe must be supported every three feet. Wall straps are available for this purpose, also when running horizontal pipe clearances to combustibles must be maintained. (2” [5cm] top, 1½” [3.8 cm] sides, 1½ [3.75 cm] bottom.)

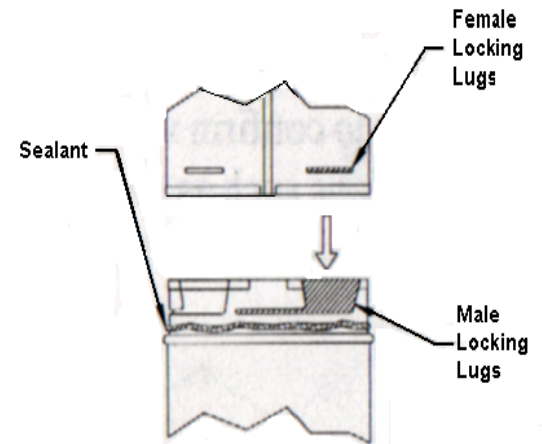

FIG. 10

STEP 3. With the pipe attached to the stove into the correct location, mark the wall for a 10-inch (25.4cm) x 10-inch (25.4cm) square hole. The center of the square hole should match the centerline of the horizontal pipe. Cut and frame the 10-inch (25.4cm) x 10-inch (25.4cm) hole in the exterior wall where the vent will be terminated. If the wall being penetrated is constructed of non-combustible material i.e. masonry or concrete, a 7-inch (17.8cm) hole is acceptable.

STEP 4. Position the horizontal vent termination in the center of the 10-inch (25.4cm) square hole, and attach to the exterior wall with the four screws provided. Before attaching the Vent Termination to the exterior wall, run a bead of non-hardening mastic around the edges, so as to make a seal between the termination and the wall. The arrow on the vent termination should be pointing up, insure that the proper clearances to combustible materials are maintained.

STEP 5. Before connecting the horizontal run of the vent pipe to the vent termination, slide the black decorative wall thimble cover over the vent pipe.

STEP 6. Slide the appliance and vent assembly towards the wall, carefully inserting the vent pipe into the cap assembly. It is important that the vent pipe extend into the vent cap a sufficient distance with a minimum of 1 ¼inch overlap. Secure the connection between the vent cap pipe and the vent cap by attaching the two sheet metal straps extending from the vent cap assembly into the outer wall of the vent pipe. Use the two sheet metal screws provided to connect the straps to the vent pipe. Bend any remaining portion of the sheet metal straps back towards the vent cap, so the decorative wall thimble FIG-13 will conceal it.

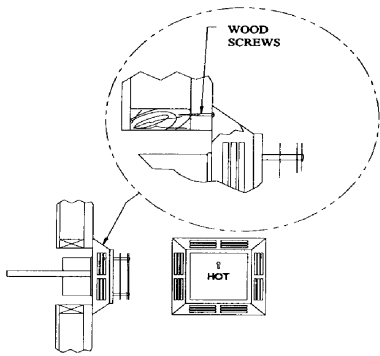

FIG. 11

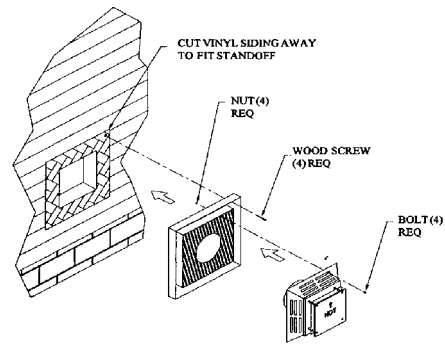

FIG. 02

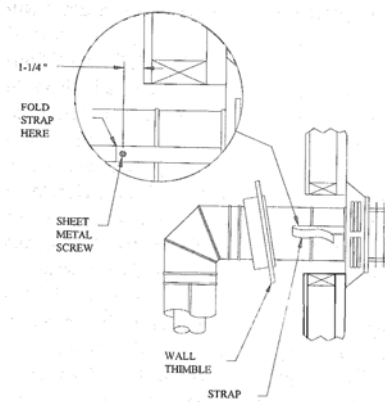

FIG. 13

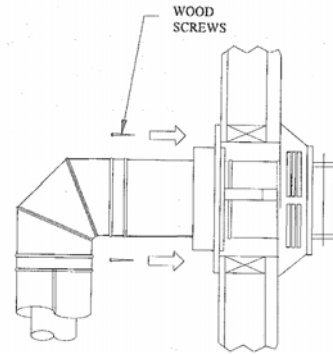

FIG. 14

STEP 7. Slide the decorative wall thimble up to the wall surface and attach with the screws provided. Apply decorative brass or chrome trim if desired. FIG-14.

NOTES: (1) The four wood screws provided should be replaced with the appropriate fasteners for stucco, brick, concrete, or other types of siding.

(2) For buildings with vinyl siding, a vinyl siding standoff (950) should be installed between the vent cap and the exterior wall FIG-12. Attach the vinyl siding standoff to the horizontal termination. The vinyl siding standoff prevents excessive heat from possibly melting the vinyl siding material. **NOTE:** that the horizontal vent termination bolts onto the flat portion of the vinyl siding standoff (shaded area in FIG-12), so that an air space will exist between the wall and the vent termination.

NOTES: (1) The horizontal run of vent pipe must be level and **should have a ¼ inch rise for every 1' of run towards the termination.** Never allow the vent to run downward. This could cause high temperature and may present the possibility of a fire

(2) The location of the horizontal vent termination on the exterior wall must not be easily blocked or obstructed. Termination clearances are as follows:

(3) When installing a vent pipe in chase the minimum clearance to combustibles is 2" inches (50 mm).

VERTICAL INSTALLATION

- STEP 1. Check the instructions for required clearances (air spaces) to combustibles when passing through ceilings, walls, roofs, enclosures, attic rafters, or other nearby combustible surfaces. Do not pack air spaces with insulation.
- STEP 2. Set the gas appliance in the desired location. Drop a plumb bob down from the ceiling to the position of the appliance flue exit, and mark the location where the vent will penetrate the ceiling. Drill a small hole at this point. Next, drop a plumb bob from the roof to the hole previously drilled in the ceiling, mark the spot where the vent will penetrate the roof. Determine if ceiling joists, roof rafters, or other framing will obstruct the venting system. You may wish to relocate the appliance, or to offset, to avoid cutting load bearing members.
- STEP 3. To install the Round Support Box/Wall Thimble in a flat ceiling, cut a 10- inch square hole in the ceiling, centered in the hole drilled in Step 2. Frame the hole as shown in FIG-16.
- STEP 4. Assemble the desired lengths of black pipe and elbows necessary to reach from the appliance adapter up through the Round Support Box. Insure that all pipe and elbows connections are in their fully twist-locked position.
- STEP 5. Cut hole in the roof centered on the small hole placed in the roof from Step 2. The hole should be of sufficient size to meet minimum requirements for Clearance to Combustibles, as specified. Continue to assemble lengths of pipe and elbows necessary to reach from the ceiling Support Box up through the roofline. Galvanized pipe and elbows may be utilized in the attic, as well as above the roofline. The galvanized finish is desirable above the roofline, due to the higher corrosion resistance.
- STEP 6. Once the pipe sections have been joined, and run up through the hole in the roof, slip an elbow strap (Part-989) over the exposed sections, bend the support straps upwards, and push the Elbow Strap down to the roof level, as shown in FIG 17. Tighten the clamp around the Pipe section. Use a level to make sure the pipe is truly vertical. With roofing nails, secure the support straps to the roof. Seal the nails holes heads with non-hardening mastic. Trim the excess length of the support straps that extend out beyond the edge of the flashing.
- STEP 7. Slip the flashing over the pipe section protruding through the roof. Secure the base of the flashing to the roof with roofing nails. Use a non-hardening sealant between the uphill edge of the flashing and the roof. Insure the roofing material overlaps the top edge of the flashing as shown in FIG 17. Verify that you have at least the minimum clearance to combustibles at the roofline.
- STEP 8. Continue to add pipe sections until the height of the vent cap meets the minimum code requirements. FIG 22. Note that for steep roof pitches, the vent height must be increased. In high wind conditions, nearby trees, adjoining roof lines, steep pitched roofs, and other similar factors can result in poor draft, or down drafting. In these cases, increasing the vent height may solve the problem.
- STEP 9. Slip the Storm Collar over the pipe, and push it down to the top of the roof flashing as shown in FIG 17. Use the non-hardening sealant around the joint between the pipe and the Storm Collar.
- STEP 10. Twist-lock the vent cap.

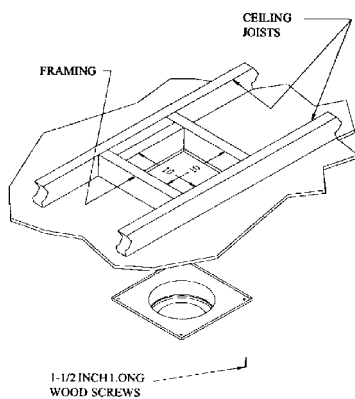

FIG-16

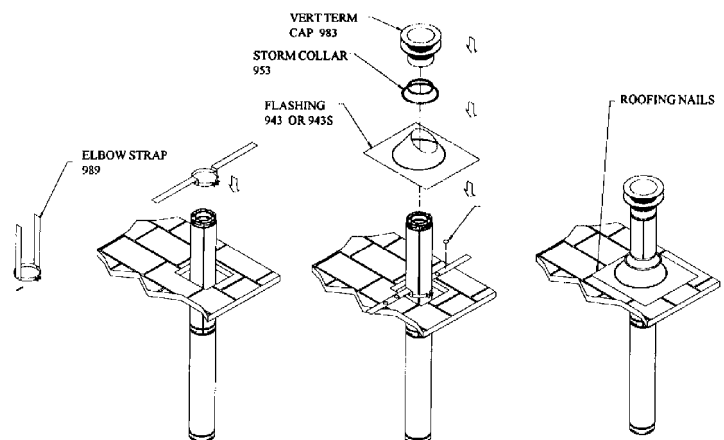

FIG-17

NOTES:

- (1) If an offset is necessary in the attic to avoid obstructions, it is important to support the vent pipe every 3 feet (90cm), to avoid excessive stress on the elbows, and possible separation. Wall straps are available for this purpose. FIG-18
- (2) When ever possible, use 45° degree elbows instead of 90° degree elbows. As the 45° elbows offer less restriction to the flow of flue gases and intake air.

NOTES:

- (1) For multi story installations. A ceiling firestop (part 963) is required at the second floor, and any subsequent floors. FIG-19. The opening should be framed to 10-inch (25.4cm) x 10-inch (25.4cm) inside dimensions, in the same manner as shown in FIG-16.
- (2) Any occupied areas above the first floor, including closets and storage spaces, which the vertical vent passes through, must be enclosed. The enclosure may be framed and sheetrocked with standard building materials. However consult the appliance manufactures installation instructions for the minimum allowable clearance between the outside of the vent pipe, and the combustible surfaces of the enclosure. Do not fill any required air spaces with insulation.

FIG. 18

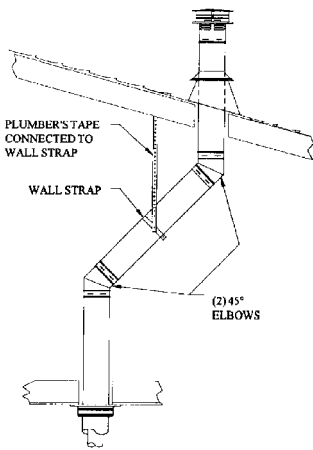

FIG. 19

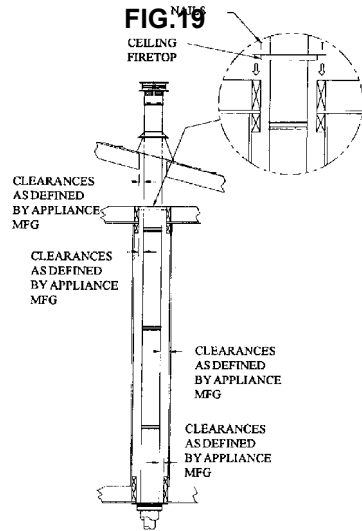

FIG. 20

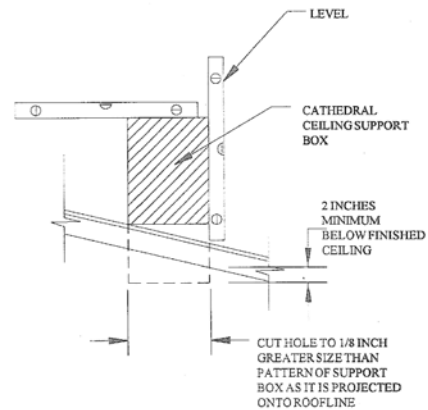

FIG. 20

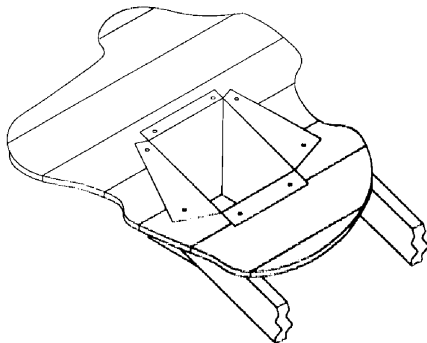
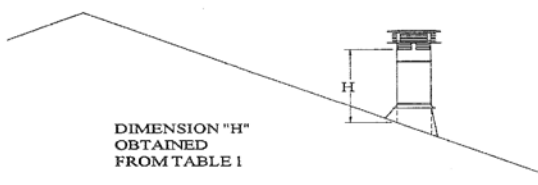

FIG-21

| ROOF PITCH | MINIMUM HEIGHT | |
|---------------------|----------------|--------|
| | FEET | METERS |
| FLAT TO 7/12 | 1 | 0.3 |
| OVER 7/12 TO 8/12 | 1.5 | 0.46 |
| OVER 8/12 TO 9/12 | 2 | 0.61 |
| OVER 9/12 TO 10/12 | 2.5 | 0.76 |
| OVER 10/12 TO 11/12 | 3.25 | 0.99 |
| OVER 11/12 TO 12/12 | 4 | 1.22 |
| OVER 12/12 TO 14/12 | 5 | 1.52 |
| OVER 14/12 TO 16/12 | 6 | 1.83 |
| OVER 16/12 TO 18/12 | 7 | 2.13 |
| OVER 18/12 TO 20/12 | 7.5 | 2.29 |
| OVER 20/12 TO 21/12 | 8 | 2.44 |

CATHEDRAL CEILING INSTALLATION

STEP 1. Follow installation steps 1 and 2 under Vertical Termination.

STEP 2. Using the plumb bob, mark the centerline of the venting system on the ceiling and drill a small hole through the ceiling and roof at this point. From the roof, locate the drill hole and mark the outline of the “Cathedral Ceiling Support Box”.

STEP 3. Remove shingles or other roof coverings as necessary to cut the rectangular hole for the “Support Box”. Cut the hole 1/8” larger than the “Support Box” outline.

STEP 4. Lower the “Support Box” through the hole in the roof until the bottom of the “Support Box” protrudes at least 2-inches below the ceiling (FIG-20) Then aligning the “Support Box” both vertically and horizontally with a level. Temporarily tack the “Support Box” into place through the inside walls and into the roof sheathing.

STEP 5. Using tin snips, cut the “Support Box” from the top corners down to the roofline, fold the resulting flaps over the roof sheathing (FIG-21). Before nailing it in to the roof, run a bead of non-hardening mastic around the top edges of the “Support Box”, to make a seal between the box and the roof. Clean out any combustible material from the inside of the “Support Box”.

STEP 6. Complete the cathedral ceiling installation by following the same procedures outlined in Steps 4 through 9 for “Vertical Termination”.

SHERWOOD INDUSTRIES LTD VENTING KITS

Inspect this kit to ensure this kit is complete and there is no damage to any of the components. If damage is present contact your dealer or your courier company. If some components are missing or damaged do not attempt the installation.

Decide on a location for the unit that will meet any or all, local code requirements. Refer to sections in this manual. Deciding Where To Locate Your Stove, and Planning Your Installation.

Set the appliance in the desired location. Check to determine if any wall studs, electrical wiring or plumbing pipes are in the way of the venting system as it passes through the wall. If obstructions are found in the wall it may be required to adjust the location of the appliance.

Set the appliance in the desired location. Temporarily place the 24” section of pipe (without the crimped end) on the unit and install the 90° elbow pointing in the direction that the vent will exit the structure. Project a level line from the center point of the elbow. Using this center point, scribe a 10” hole or square on the wall. Cut the hole out on both the interior and exterior wall surfaces. Install the wall thimble and secure this thimble on both the inner and outer wall surfaces.

With the appliance still in place install the 24” horizontal section on the elbow and let this section of pipe protrude through the exterior wall. Mark this pipe so that it is flush with the exterior surface and cut this section of pipe.

Dismantle the outer pipe sections.

Remove the 4” flue collar from the unit and remove any loose sealant, install the new 4” diameter x 5” high flue collar provided in this kit.

Attach the flexible liner to the vent termination cap by placing a small bead of mil-pac sealant on the vent terminal and slide the flex liner onto the vent terminal and secure with 3 sheet metal screws evenly spaced.

Dress the flex liner through the wall thimble and attach the vent terminal to the outside of the house using 4 wood screws provided. (The use of non-hardening mastic should be used around the vent to ensure a watertight seal.)

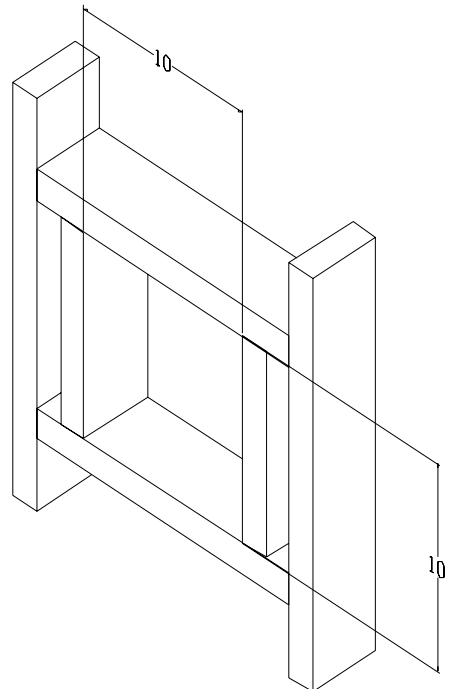

Install 2 spring spacers around the flex pipe. Slide the horizontal section of pipe over the flexible liner and install through the wall thimble ensure that this portion of pipe slides onto the vent termination cap. Slide the inside finished collar over the horizontal section of pipe and secure to wall using the screws provided. Slide the 90° elbow over the flex pipe. Stretch the flex liner to a length long enough to ensure the flex liner can be easily connected to the flue outlet of the appliance. Install the remaining spring spacers over the flexible liner and install the vertical section of pipe (DO NOT SLIP THESE SECTIONS OF PIPE TOGETHER, YOU WILL REQUIRE SOME MOVEMENT IN THESE PIPE SECTIONS IN ORDER TO SECURE THE FLEX PIPE TO THE FLUE OUTLET ON THE APPLIANCE.)

Place a bead of high temperature silicone on the flue pipe and slide flex liner over collar, secure the flex liner with 3 sheet metal screws evenly spaced.

Align all straight sections of pipe, slipping all joints together and installing 3 sheet metal screws evenly spaced.

A small can of touch up paint has been supplied with this kit. Lightly touch up any scratches that might have occurred during the installation process.

Install brass decorative rings around each joint making sure this decorative ring covers the sheet metal screws which secure each section of pipe together and secure to vent pipe in the slotted tab on the backside of the pipe so that the fastener would not be easily seen.

Secure the horizontal section of pipe to the inside finished collar by installing a screw in the tab on the inside finished collar. (THIS WILL PREVENT THE PIPE FROM BEING DISCONNECTED AT THE VENT TERMINAL.)

Light the appliance and ensure proper operation.

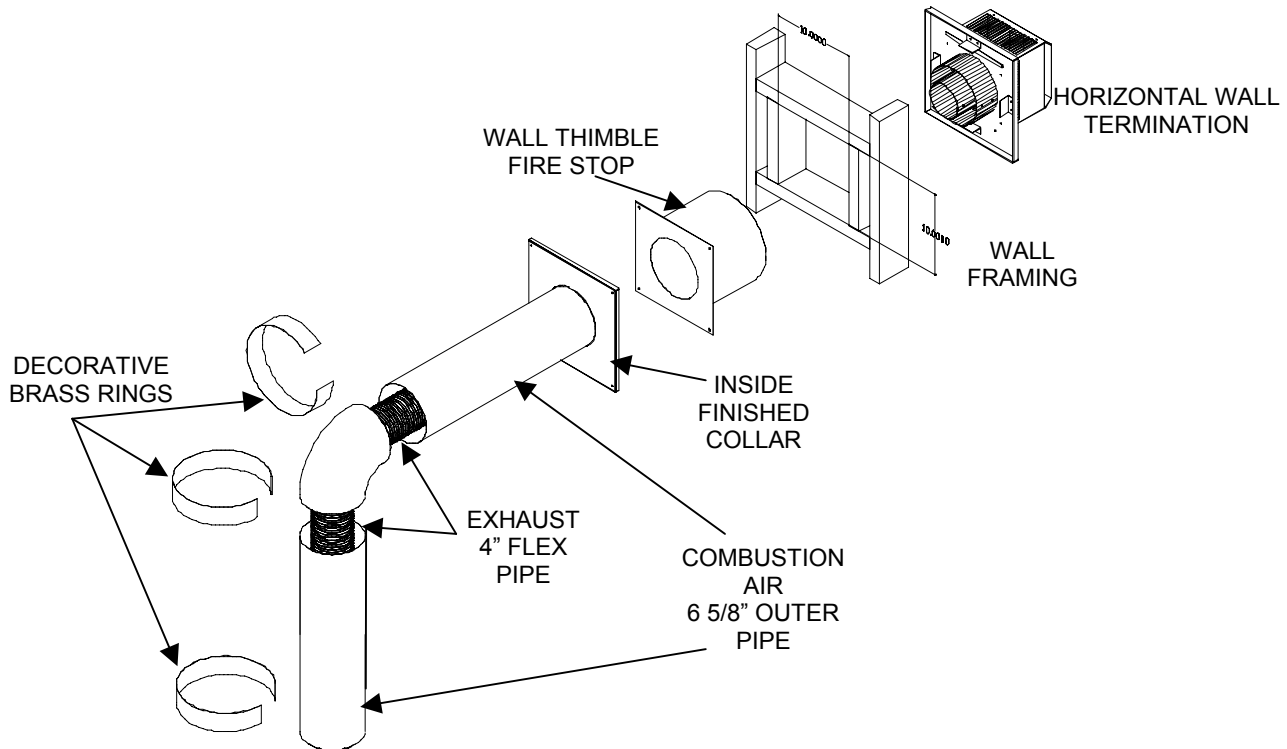
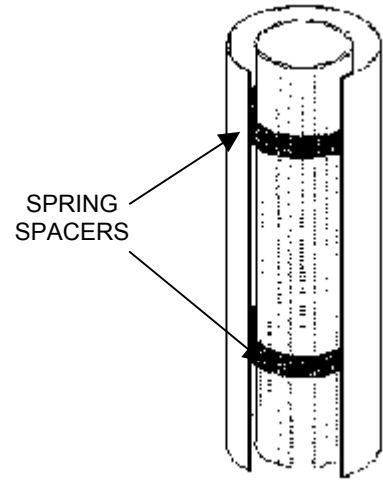

VENTING INTO CLASS "A" CHIMNEYS

This model is also certified and tested to vent into CLASS "A" wood stove chimneys. Place the freestanding direct vent appliance in the desired location.

Using Simpson Dura Vent conversion kit #s 931-932-933, depending on the ID diameter of the CLASS "A" chimney that this appliance is to be vented into.

Place a bead of high temperature silicone or Mil-Pac at each connection to ensure a tight seal.

NOTE: A 4" flex liner must be used in the application.

NOTE: Use Simpson Dura Vent from the top of the appliance until this vent reaches the CLASS "A" chimney. Install the retro adapter to the top section of GS direct vent pipe and install the flex liner to the retro adapter.

Fully liner the CLASS "A" chimney with a minimum 4" flex liner to the top of the CLASS "A" chimney.

Placing a bead of high temperature silicone to the Simpson Cap adapter and securely attach the flex liner to the adapter.

Secure the cap adapter to the CLASS "A" chimney ensuring an airtight seal.

Install the vertical termination cap.

Light the unit and ensure proper operation.

THE USE OF ANY EXISTING CHIMNEY AS AN AIR INTAKE IS NOT COVERED UNDER THE ANSI Z21.88-1999 - CSA 2.33-M99 TEST METHODS AND THE RESULTING ITS/WHI PRODUCT CERTIFICATION. THE CODE AUTHORITY HAVING JURISDICTION MUST BE CONSULTED PRIOR TO PROCEEDING WITH THIS INSTALLATION METHOD.

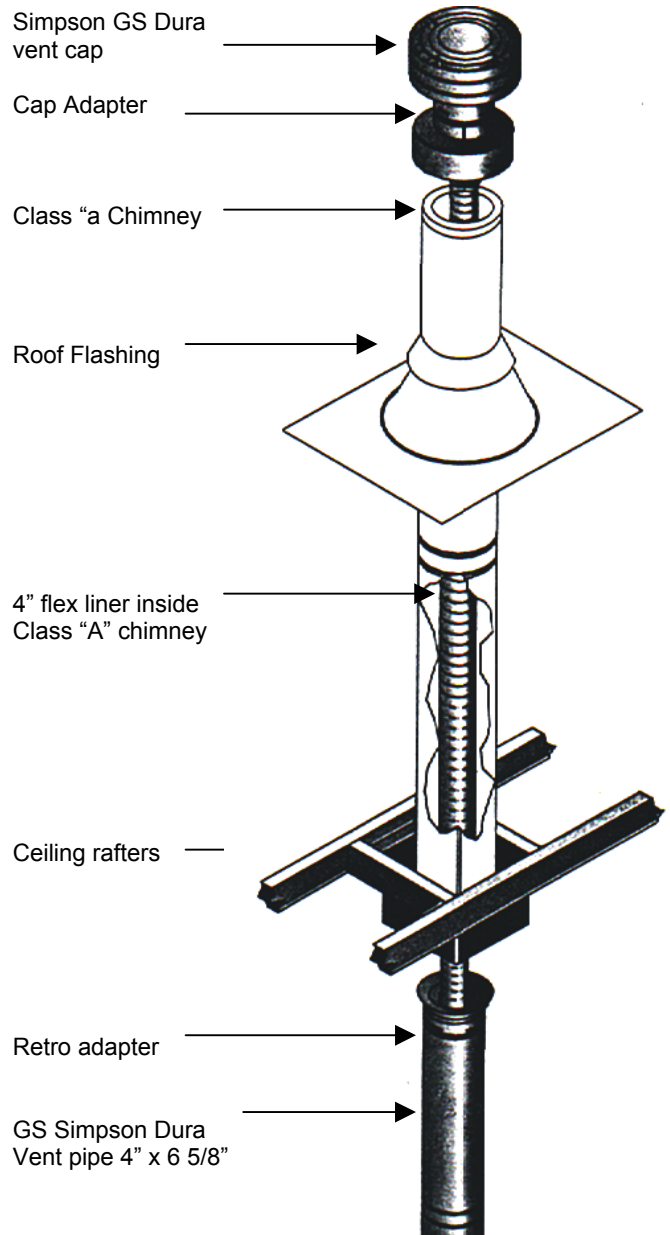

Mobile Home

- **When the unit is installed in a Mobile Home it must be grounded to the steel chassis or connected to a grounding rod.**

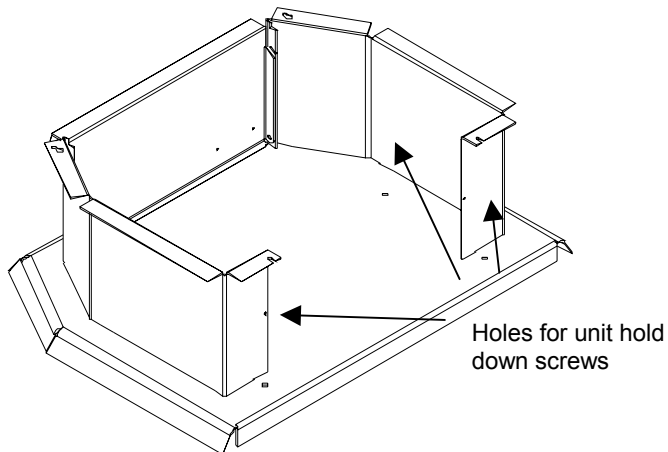

- **In a Mobile Home installation the unit must be bolted securely to the floor using the holes provided.**
- Manufactured (mobile) home installation must be in accordance with the Manufactured Home Construction and Safety Standard, UL 307B, Title 24 CFR, Part 3280 and/or The Standard for Manufactured Home Installations, ANSI A225.1/NFPA 501A

INSTALLATION OF LOGSET and EMBERS

INSTALLING THE GLOWING EMBERS

A bag of Rock Wool embers is provided for use on the burner.

CAUTION: Use only the type of ember material supplied with this appliance. Due to the amount of ember material there may be more than required.

If over time, through cleaning and servicing, these embers require replacement, contact the nearest ENVIRO dealer for replacement embers.

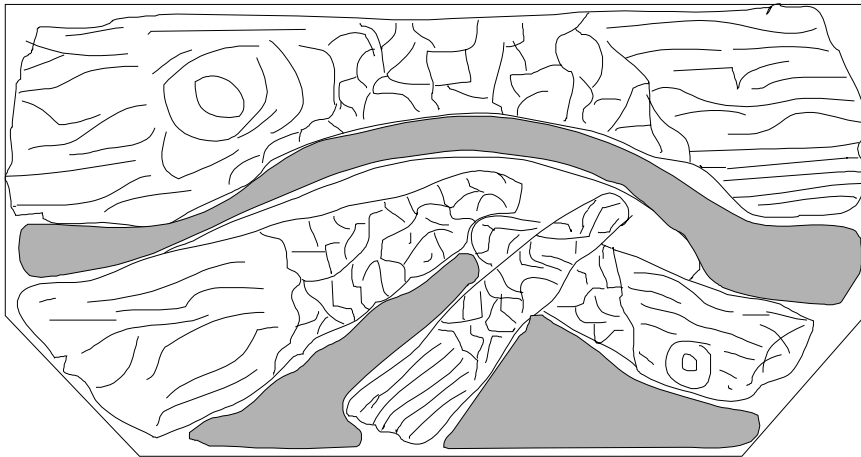

Remove the ember material from the plastic bag. Cover the shaded areas in the diagram shown beside. Totally fill these areas with glowing ember material.

DO NOT PACK DOWN. LEAVE EMBER MATERIAL LOOSE.

CAUTION: NEVER OPERATE THIS APPLIANCE WITH THE DOOR REMOVED

INSTALLING THE LOGSET

Carefully remove logs from box. Check to ensure there is no damage. It is very important to install these logs in their proper position to insure safe, optimum operating conditions.

- Open the front door.
- Place each piece of the log set into the firebox resting on the pins provided. Ensure that the holes in logs line up.
- Close the door and tighten securely.

Upon the first light up, watch for ignition to **all** burner ports. If a long delay is noted:

- First, wait for the appliance to cool down
- Open the front door of the appliance.
- Check to carefully re-position the embers making sure that burner ports are not plugged solid or blocked.

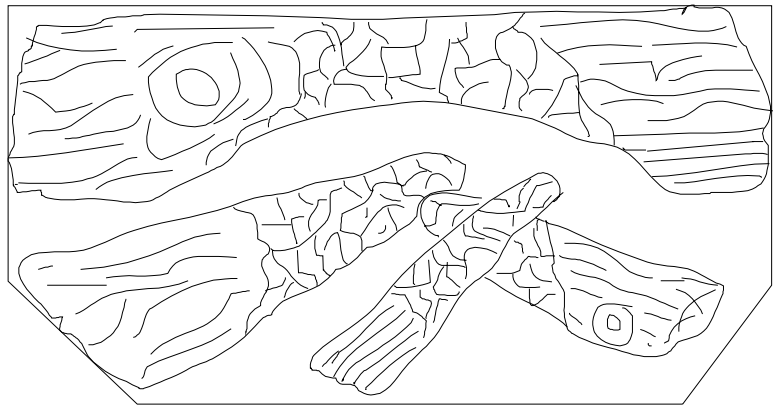

(See adjusting the venturi section to adjust air for proper flame).

IMPORTANT NOTE: When the unit is turned on for the first time, it should be turned onto high without the fan on for the first 4 hours. This will cure the paint, logs, gasket material and the other products used in the manufacturing process. It is advisable to open a window or door, as the unit will start to smoke and can irritate some people. After the unit has gone through the first burn turn the unit off including the pilot, let the unit get cold then remove the glass door and clean it with a good glass fireplace glass cleaner, available at your local ENVIRO dealer. (See page 16.glass cleaning.)



OPERATING INSTRUCTIONS

FOR YOUR SAFETY READ BEFORE OPERATING

WARNING: IF YOU DO NOT FOLLOW THESE INSTRUCTIONS EXACTLY, A FIRE OR EXPLOSION MAY RESULT CAUSING PROPERTY DAMAGE, PERSONAL INJURY OR LOSS OF LIFE.

- A) This appliance is equipped with a pilot, which must be lit by hand by following these instructions exactly.
- B) BEFORE LIGHTING smell all around the appliance area for gas, and next to the floor because some gas is heavier than air and will settle on the floor.
- WHAT TO DO IF YOU SMELL GAS:**
- Do not try to light any appliance.
 - Do not touch any electrical switch; do not use any phone in your building.
 - Immediately call your gas supplier from a neighbor's phone. Follow the gas supplier's instructions.
- C) If you cannot reach your gas supplier, call the fire department.
- C) Use only your hand to push in or turn the gas control knob. Never use tools. If the knob will not push in or turn by hand, do not try to repair or force it call a qualified service technician. Force or attempted repair may result in a fire or explosion.
- D) Do not use this appliance if any part has been under water. Immediately call a qualified service technician to inspect the appliance and to replace any part of the control system and any gas control which has been under water

LIGHTING INSTRUCTIONS

1. STOP! Read the safety information above.
2. Turn off all electrical power to the appliance.
3. Turn the gas control knob clockwise  to the "off" position.
4. Open door. **Wait five (5) minutes to clear out any gas.** Close door. If you smell gas including near the floor, **STOP!** Follow "B" in the above safety information. If you don't smell gas go to next step.
5. Find the pilot located to the right between the front and rear burner.
6. Turn gas control knob counter-clockwise  to "PILOT".
7. Push the gas control knob in fully and hold. Immediately light the pilot by pushing the piezo spark ignitor. Keep knob depressed for about 30 seconds after pilot is lit. Release knob. If pilot goes out, repeat steps 4 through 6. **WARNING** The gas valve has a lockout device, which will not allow the pilot burner to be re-lit until the thermocouple, has cooled. If the knob does not pop up when released, stop and immediately call your service technician or gas supplier.

If the pilot will not stay lit after several tries, turn the gas control knob to "OFF" and call you service technician or gas supplier.

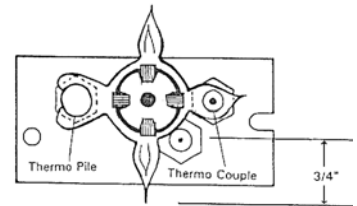

8. Turn gas control knob counter-clockwise  to the "ON" position. Flip burner switch to "ON" then turn "HI / LO" knob to the desired setting.

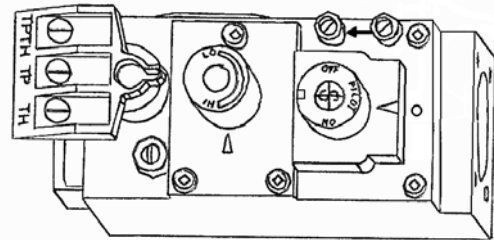

HI \ LO knob Control knob

NOTE: Check to be sure the pilot flame engulfs the thermocouple and that the burners light completely.

9. Turn on all electrical power to the unit

TO TURN OFF GAS TO APPLIANCE

1. Turn the gas control knob clock-wise  to "OFF" DO NOT FORCE
2. Turn off all electrical power to the appliance if service is to be performed.
3. Flip burner switch to off.

MAINTENANCE AND TECHNICAL

Periodically check to ensure that your "Direct Vent" system is clear.

Periodically check the pilot and burner. Check to see that all the burner ports are clean and clear. Check the pilot head for blockage. Check to ensure the pilot flame is blue with small yellow tips.

OPENING THE DOOR

Caution door is hot when in operation.

1. Open the right hand hinged side flap, which will expose a door fastener. Using a 1/2" wrench, loosen the fastener.
2. Due to the shape of the bay window door. You must also open the left-hand side flap before attempting to open the door.

CLEANING OF GLASS

Do not clean glass when hot

It will be necessary to clean the ceramic glass periodically. During a cold start up, condensation will sometimes form on the glass this is a normal condition with all gas fireplaces and stoves. However, this condensation can allow dust and lint to cling to the glass surface. Initial paint curing of the appliance can leave behind a slight film on the glass. This is a temporary problem. It is therefore recommended that the glass be cleaned initially after the first burn in period of the unit.

After that, depending upon the amount of use, cleaning should be required no more than two or three times per season.

To clean the door, use a mild glass cleaner and a soft cloth. Abrasive cleaners will damage the glass and gold surfaces. Close door tightly.

TO REPLACE DOOR AND GLASS ASSEMBLY

The glass in this appliance is an integral part of the door assembly. If the glass is damaged or broken., a replacement glass assembly must be fitted by your ENVIRO dealer.

To Replace:

- Open door fully
- Lift door vertically so that hinge pins lift out of hinge receivers.
- Return the door assembly to dealer.

**The door and glass assembly must be replaced as a complete unit. By your ENVIRO Dealer.
No substitute materials are allowed.**

FOR CLEANING THE INSIDE OF THE FIREBOX

Remove the log carefully from the firebox. Gently remove the embers and place on a piece of paper towel, until ready to replace.

Vacuum the firebox thoroughly. Carefully clean off any dust on the logs and remove any lint from the main burner and pilot burner.

After carefully replacing the log and embers in their correct positions, and the door has been resealed, re-light the pilot, following the instructions on the attached label.

CLEARANCES MUST BE SUFFICIENT TO ALLOW ACCESS FOR MAINTENANCE AND SERVICE

TROUBLE SHOOTING

| Problem | Possible Cause | Solution |
|---|---|---|
| Spark will not light the pilot after repeated pressing of spark Ignitor | Defective piezo Ignitor | Check connections to Ignitor -If Ignitor connections are good but there is no spark-replace Ignitor |
| | Broken spark electrode | -Check for broken ceramic insulation replace, electrode if broken |
| | Miss-aligned spark electrode | -If spark is not arcing from the electrode to pilot- adjust by loosening screws on pilot base. Adjust and re-tighten |
| Pilot will not remain lit | Problem with thermocouple circuit | -Check for proper connection of thermocouple to rear of valve. If loose, tighten lightly -Check pilot for full flame impingement around thermocouple. If the pilot is too small - Check gas pressure, adjust pilot rate screw check pilot head for blockage. -Check thermocouple voltage at valve- must be greater than 5 mV. If low, replace thermocouple. |
| | Air in gas line - (Pilot flame dies while knob is depressed.) | -Bleed line. -Check gas line pressure. -Contact dealer. |
| Burners will not remain lit | Problem with thermopile circuit | -Check gas line pressure. -Check for flame impingement on thermopile, if low see "Pilot will not stay lit" -Check thermopile for a Minimum of 300 mV when burner switched on. -Check wiring to thermostat for breaks. |
| Flame lifting | Leak in vent pipe Improper vent configuration Terminal may be recirculating flue gases | -Check for leaks in vent connections -Check vent configuration with manual -Check to see if terminal is on correctly -May need to install high wind termination cap -Contact dealer. |
| Glass fogs up | Normal conditions - after the appliance warms up glass will clear ** Due to additives in gas, glass may get hazy during normal use** Clean when needed. | |
| Blue flames | Normal during start - flame will yellow as the appliance heats up. | |
| Flames are burning "dirty" or Sooting | Flame impingement | -Check log position -Increase primary air by opening venturi shutters See also "Burners will not stay lit" |

GAS LINE CONNECTION

ORIFICE SIZES, PRESSURE AND BTU'S

| | <u>NATURAL GAS</u> | <u>PROPANE GAS</u> |
|--------------------------------|-------------------------------|-------------------------------|
| Main Orifice | #43dms | #53dms |
| Manifold pressure. | 3.8"wc (0.95kPa) | 11"wc (2.74kPa) |
| Min. Manifold pressure. | 1.1"wc (0.27kPa) | 2.7"wc (0.67kPa) |
| Supply Pressure. | 7.0"wc (1.74kPa) | 12"wc (2.98kPa) |
| Min. Supply pressure. | 5"wc (1.25kPa) | 11.5"wc (2.86kPa) |
| Max. BTUH Input. | 26,500 Btu/h (7.87 kW) | 26,500 Btu/h (7.87 kW) |
| Min. BTUH Input. | 13,500 Btu/h (3.9 kW) | 13,500 Btu/h (3.9 kW) |
| Output fan off | 21,000 Btu/h (6.15 kW) | 21,500 Btu/h (6.3 kW) |
| Output fan on | 21,500 Btu/h (6.3 kW) | 22,000 Btu/h (6.45 kW) |

High Altitude Canada 0-4500 ft. (1372m), in the USA use ANSI Z223.1

WARNING: Only persons licensed to work with gas piping may make the necessary gas connections to this appliance.

NOTE: The gas line connection may be made using 3/8" rigid tubing or an approved flex connector. Since some municipalities have additional local codes it is always best to consult your local authorities and the CAN/CGA-B149 (1 or 2) Installation Code. For USA gas installations follow either local codes or the current edition of the National Fuel Gas Code ANSI.Z223.1.

UPON CONNECTION, MARK APPROPRIATE FUEL TYPE ON RATING LABEL LOCATED ON THE INSIDE OF THE RIGHT HAND SIDE PANEL.

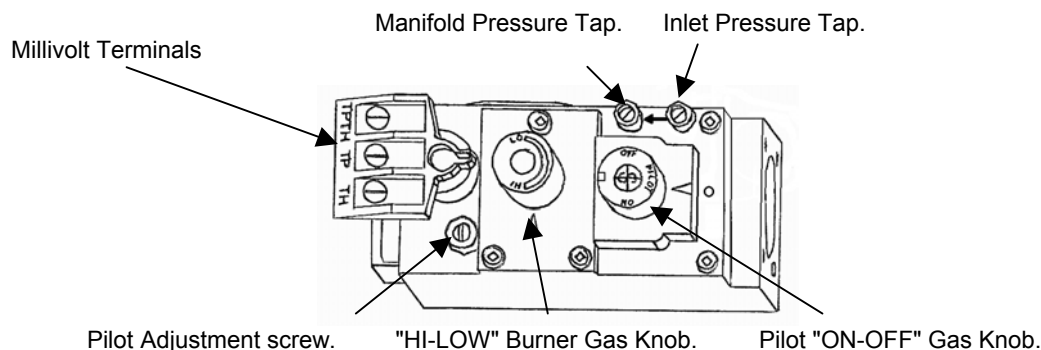

The appliance and its shutoff valves must be disconnected from the gas supply piping system during any pressure testing where the pressure exceeds 1/2 PSIG (3.45 kPa) or damage will occur to the valve.

The appliance must be isolated from the gas supply piping system by closing its individual manual shutoff valve during any pressure testing of the gas supply piping system at test pressures equal to or less than 1/2 psig (3.5 kPa).

When using copper or flex connectors use only fittings approved for gas connections.

TO TEST

The pressure taps are located in the top right corner on the valve face (right - inlet, left - manifold pressure).

- Turn setscrew counter clockwise to loosen, 2 turns.
- Place 5/16" hose over pressure tap system.
- When finished, release pressure, remove hose & tighten setscrew.

Always check for gas leaks with a soap and water solution after completing the required pressure test.

NEVER USE AN OPEN FLAME FOR LEAK TESTING

ELECTRICAL

The **ENVIRO EG 28.FS.DV**. Will operate with no external power supply. These models have a Millivolt gas control valve that uses the pilot flame to generate enough electricity to operate the main burner.

The appliance when installed must be electrically connected and grounded in accordance with local codes or in the absence of local codes, with the current CSA C22.1 CANADIAN ELECTRICAL CODE. Part 1, SAFETY STANDARDS FOR ELECTRICAL INSTALLATIONS, or THE NATIONAL ELECTRICAL CODE ANSI / NFPA 70 in the USA.

NOTE:

- Operation of the fan increases the efficiency and the heat output of the appliance.
- The thermostat connects to the two purple wires in the harness
- Control panel light uses a 7w max. bulb
- **If the unit is installed in a Mobile Home it must be connected to a grounding rod.**
- **If the unit is installed in a Mobile Home it must be bolted securely to the floor.**

CAUTION
Label all wires prior to disconnection when servicing controls. Wiring errors can cause improper and dangerous operation. Verify proper operation after servicing.

WARNING: ELECTRICAL GROUNDING INSTRUCTIONS.
This appliance is equipped with a three-prong (grounding) plug for your protection against shock hazard and should be plugged into a properly grounded three-prong receptacle. **DO NOT** cut or remove the ground prong from the plug.

ENVIROGAS-28 Wiring Diagram

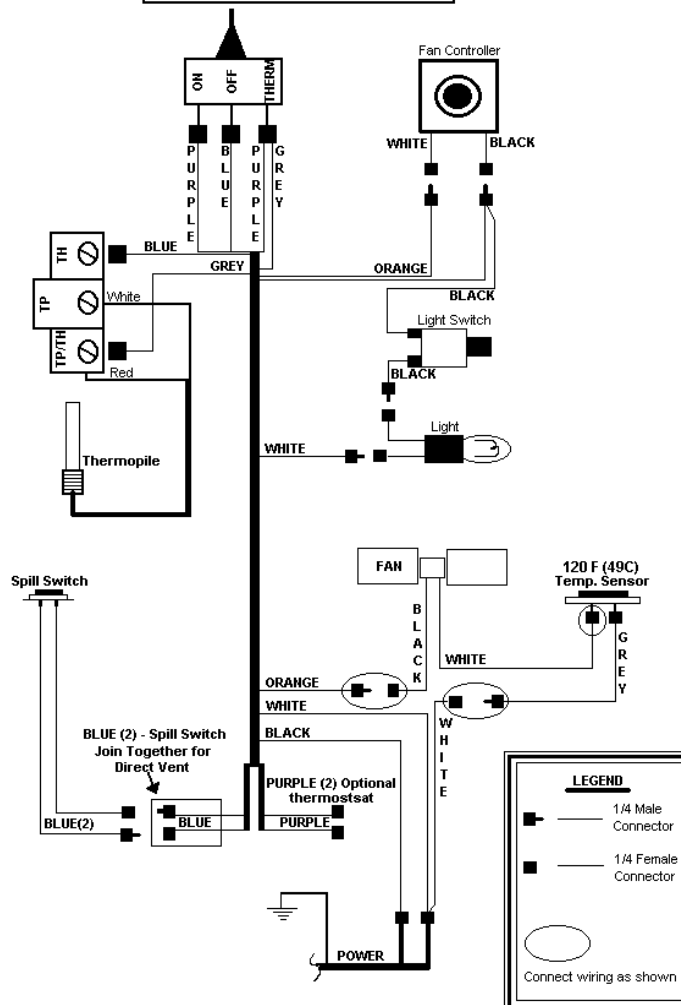

INSTALLING REMOTE THERMOSTAT OR WALL SWITCH

RECOMMENDED WIRE SIZE for thermostat installation: 18 Gauge, 2 wire solid core, Low Voltage wire. (Bell wire)

1. Install the 18 Gauge wire supplied to the two terminals on the thermostat or remote wall switch.
2. Connect the other end of the wire to the gas valve using the two outside terminals on the front of the gas valve. Use the terminals marked (TP/TH and TH).

RECOMMENDED MAXIMUM LEAD LENGTH (TWO WIRE) WHEN USING WALL THERMOSTAT

| WIRE SIZE | MAXIMUM LENGTH |
|-----------|----------------|
| 14 GAUGE | 100 FEET |
| 16 GAUGE | 64 FEET |
| 18 GAUGE | 40 FEET |
| 20 GAUGE | 18 FEET |

PARTS AND ACCESSORIES

Service Parts available from your local Enviro Dealer

Burner Control Assembly
Natural Gas Pilot Assembly
Propane Pilot Assembly
Door Bolt
Relief Door Gasket
Regulating Valve
Piezo Ignitor
Burner Switch
B-vent Spill switch 220°
Orifice Blank

Convection Blower
Light Bulb Holder
Light Switch (momentary)
Fan Controller
Log Set (with Embers)
Thermocouple
Embers
Thermopile
Door Gasket
Convection Fan Sensor 120° (48°C)

Accessories

Gold trim Package
Low Voltage Thermostat

INSTALLING OR REMOVING THE BLOWER

The blower does not require lubrication.

1. Turn the unit off and remove the log set.
2. Remove the burner tray assembly by removing the screw on either side of the tray, between the front and rear burners. Lift the tray out.
3. Remove the 4-5/16" bolts that hold the blower mounting plate to the back firewall. Use a light lubricating oil on screws before removal.
4. Carefully pull the assembly into the firebox. Install the blower onto the mounting bracket (blower outlets pointing through the two holes in the bracket) using the 4 screws provided.
5. Connect wires according to the wiring diagram. (If removing the blower, disconnect the blower leads from the harness. Remove the blower.)
6. Check mounting plate gasket and reverse steps 1 through 4 to reinstall.

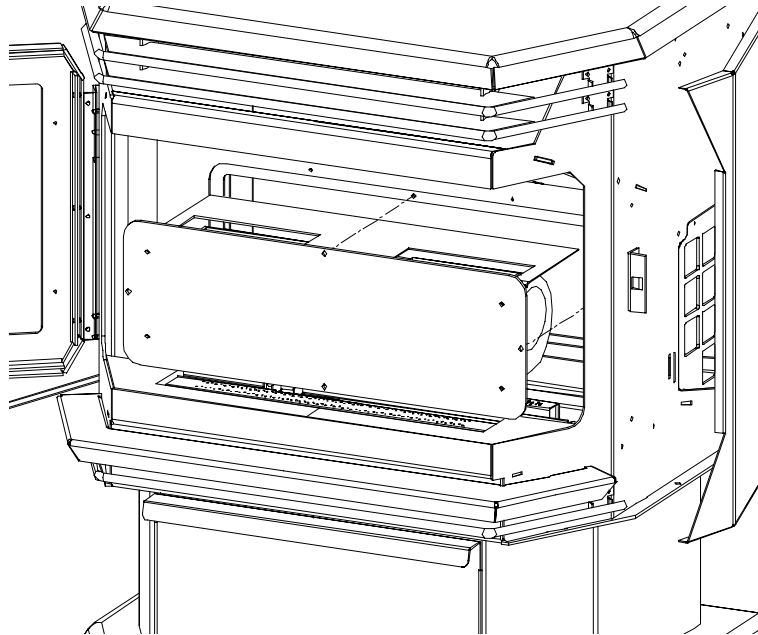

ADJUSTING THE VENTURI

- Remove the ash shelf by undoing the screw at each end, pull shelf towards you.
- Remove one screw from the cover plate located below the ash shelf. Loosen the other screw (do not remove) swing the cover plate out of the way and tighten screw down to hold it in place.
- With a long screwdriver rotate spring clips to open or close the shutter to the desired setting.
- **The burner flame should be a bright yellow/orange when hot. Excessive blue is to lean and dark orange with soot is too rich.**

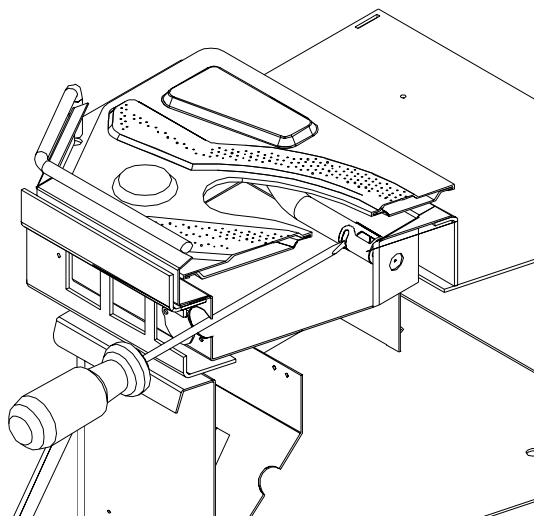

FUEL CONVERSION

“Warning”: This conversion kit shall be installed by a qualified service technician in accordance with the manufacturer’s instructions and all applicable codes and requirements of the authority having jurisdiction. If the information in these instructions is not followed exactly, a fire, explosion or CO poisoning may result. The qualified service agency is responsible for the proper installation of this kit. The installation is not proper or complete until the operation of the converted appliance is checked as specified in the owner’s conversion kit.

Please read and follow these instructions. Also please read the instruction guide lines provided by S.I.T on how to remove and install the HI-LOW regulator.

- STEP 1. Carefully inspect all parts supplied with this conversion kit.
- STEP 2. Shut the gas off and disconnect the main gas line from the unit.
- STEP 3. Open the door by unscrewing the ½” bolt on the right hand side of the stove. Lift door off the hinges mounted on the left-hand side. Remove the burner tray top for the appliance
- STEP 4. Change the regulator on the front of the gas valve. (Follow the instructions provided by S.I.T)
- STEP 5. To change the pilot orifice: First, remove the two (2) T-20 Torx screws that hold the pilot assembly to the burner tray. Lift the pilot assembly from the burner tray. Using a 10mm wrench, disconnect the pilot line from the pilot assembly and remove the pilot injector. Install the new pilot injector.
(BE CAREFUL WHEN TIGHTENING THE PILOT FITTING, YOU COULD BREAK THE CERAMIC IGNITOR ELECTRODE).
- STEP 6. Re-install the pilot assembly in the reverse order of STEP 5.
- STEP 7. Remove the burner orifice with a ½” deep socket.
- STEP 8. Install the new orifice supplied making sure that the orifice is in the correct location. Be sure to put a bead of pipe thread sealant or approved Teflon tape on the orifice before installing into the burner assembly.
- STEP 9. Re-install the burner tray, log set and door.
- STEP 10. Re-connect the gas line to the unit. Do a leak check using a soap and water solution or an approved manner on the gas supply line and the pilot tubing.
- STEP 11. Re-light the appliance to insure proper operation and proper flame appearance. Be sure to adjust the venturi setting to achieve an efficient flame in the fireplace.
- STEP 12. MAKE SURE that the sticker provided by S.I.T is installed to signify that this valve has been converted to a different type of fuel. Also make sure that the rating plate has a conversion label to show that this unit has been converted to a different fuel type.

A VISUAL CHECK OF THE REGULATOR KNOB IS NECESSARY TO DETERMINE WHETHER OR NOT THE REGULATOR IS THE CORRECT PART. A 50% TURN DOWN REGULATOR WILL HAVE ONLY ONE CORNER ON THE KNOB.

1 50% turn down HI-LOW Regulator w 3 T-20 Torx screws
 1 T-20 tamper proof Torx screwdriver bit
 1 pilot injector
 1 Main orifice

| | | |
|----------------------------------|-------------|---------|
| 1 Pilot assembly mounting gasket | | |
| | NATURAL GAS | PROPANE |
| Pilot Orifice. | .62mm | .35mm |
| Burner Orifice. | #43dms | #53dms |
| Venturi Settings | 1/16” min | ¼” min |

WARRANTY

Sherwood Industries Ltd. offers a *Lifetime Warranty on this gas product. The lifetime warranty covers the appliance for a period of seven years from the date of installation. This warranty applies only to the original owner in the original location

Covered under the lifetime warranty are Cabinet Sides, Tops, Pedestals, Surround Panels and Chassis and Heat Exchanger. These steel components are covered against manufacturer's defects for parts 5 years and labor for the first year and for parts only thereafter (A) The following exclusions apply: - over-firing due to incorrect setup or tampering, damage caused by incorrect installation, usage or abuse. The unit must be properly installed by a qualified technician or installer, and must meet all local and national gas and building code requirements.

We also cover against manufacture defects under our lifetime warranty. The following components, Gold Plating, Log Set, Burners and Glass (A) These following exclusions apply: Gold plating- Damage caused by scratching, marring, chemicals, fingerprints, abrasive cleaners or discoloration with age. Glass- use of harsh or abrasive cleaners, striking the glass or surface contaminates. Logset- Damage caused by incorrect handling or misuse. Burners- damage caused by improper or continuous operation under incorrect conditions.

Sherwood Industries Ltd. offers a 2-year warranty on all the Electrical Components and Gas Components against manufacturing defects. Paint is covered against flaking. This offer includes parts and labor for 1 year and for parts only thereafter.

The paint on the Metal Brick Liner may peel. This is due to the extreme conditions applied to the paint and is no way covered under warranty.

Your dealer shall make all claims under this warranty in writing.

(A): TO A MAXIMUM OF SEVEN YEARS

WHEN FILING A WARRANTY CLAIM PLEASE COMPLETE THE FOLLOWING INFORMATION ON AN OFFICIAL WARRANTY CLAIM FORM:

To the Dealer

- Name, address and telephone number of purchaser and date of purchase.
- Date of installation. Name of installer and dealer. Serial number of the appliance. Nature of complaint, defects or malfunction, description and part # of any parts replaced.

To the Distributor

- Sign and verify that work and information are correct.

This warranty covers defects in materials and workmanship only if the product has been installed according to the manual's instructions. If the product is damaged or broken as a result of misuse or mishandling the warranty does not apply. The warranty does not cover removal and re-installation costs.

Sherwood Industries Ltd. reserves the right to repair or to replace the defective product. The shipping costs are to be paid by the consumer. All warranties by the manufacture are set forth herein and no claim shall be made against the manufacturer on any oral warranty or representation.

Sherwood Industries Ltd. and its employees or representatives will not assume any damages, either directly or indirectly caused by improper usage, operation, installation, servicing or maintenance of this appliance.

Sherwood Industries Ltd. reserves the right to make changes without notice. Please complete and mail the warranty registration card and have the installer fill in the installation data sheet in the back of the manual for warranty and future reference.

PARTS LIST

| | | | |
|----------|--|-----------|--|
| EC-001 | 120° F Ceramic Temperature Sensor | EG28-108 | Freestanding Pedestal |
| EC-002 | 220° F Ceramic Spill Switch | EG28-109 | Freestanding Pedestal Door |
| EC-006 | SIT Nova 820 NG Valve 50% | EG28-116A | Burner Tray Top (Post 2000) |
| EC-007 | SIT Nova 820 LP Valve 50% | EG28-120 | Freestanding DV Owner's Manual |
| EC-009 | Thermocouple (Post 10/00) | EG28-121 | Freestanding BV Owner's Manual |
| EC-011 | Spark Electrode w/Cable | EG28-123 | Freestanding Cabinet Side Panel |
| EC-012 | Thermopile | EG28-124 | Freestanding BV Stove Top |
| EC-013 | Pilot NG w/Electrode | EG28-125 | Firebox Baffle |
| EC-014 | Pilot LP w/Electrode | EG28-126 | Freestanding DV Stove Top |
| EC-015 | Fully Assembled Pilot NG | EG28-131 | DV Top Baffle |
| EC-016 | Fully Assembled Pilot LP | EG28-132 | BV Top Baffle |
| EC-019 | Pilot Orifice NG | EG28-139 | Wire Channel |
| EC-020 | Pilot Orifice LP | EG28-140 | Pedestal Wiring Plate |
| EC-021 | Pilot Gasket | EG28-141 | Pedestal Back |
| 50-343 | Orifice Blank - Front | EG28-143 | Burner Complete w/Nova SIT Valve NG (Post March '00) |
| EC-023 | S.I.T. Piezo Ignitor | EG28-145 | Burner Complete w/Nova SIT Valve LP (Post March '00) |
| EC-024 | SS Flex Connector with 3/8" Elbow 18" Long | EG28-150 | Ash Sill |
| EC-025 | Burner Switch (for Nova Tray) | EG28-161 | Door Hinge Brackets |
| EC-029 | Fan Access Cover Gasket | EG28-162 | Door Latch Bracket |
| 50-512 | Convection Blower | EG28-169 | BV 4" Crimped Flue Collar |
| EG28-304 | Freestanding Fan Mounting Bracket | EG28-170 | DV 4" Flared Flue Collar |
| EC-031 | Miniature Light Bulb | EG28-201 | LP to NG Conversion Kit (Post March '00) |
| EC-032 | Freestanding Light Bulb Holder | EG28-203 | NG to LP Conversion Kit (Post March '00) |
| EC-037 | Freestanding Wiring Harness | EG28-152 | Louver Bars (set of 3) – Painted |
| EF-045 | Freestanding Fan Controller | EG28-153 | Louver Bars (set of 3) – Gold |
| EC-040 | Freestanding Fan Controller Knob | 50-475 | Louver Bars (set of 3) – Nickel |
| EC-043 | IEC Power Cord 115 V | 50-757 | Outer Door Cover – Painted |
| EC-045 | Embers | 50-476 | Outer Door Cover – Gold |
| EC-048 | Log Set and Embers | 50-477 | Outer Door Cover – Nickel |
| EC-054 | 1 X 1 Side Cabinet Hinge | | |
| EC-055 | FPI Side Panel Magnet | | |
| EC-056 | Freestanding Pedestal Door Magnet | | |
| EC-057 | 3/8 Tadpole Gasket | | |
| EC-059 | Door Latch Bolt | | |
| EC-060 | Simpson Dura Vent Adapter | | |
| EC-061 | Freestanding DV Vent Kit | | |
| EC-064 | Fan Impeller | | |
| EC-065 | Door Nut Mounting Bracket | | |
| EC-066 | Light Switch | | |
| EC-067 | Vent Restrictor Rings | | |
| EG28-026 | Side Panel Magnet | | |
| EG28-027 | Side Panel Magnet Bracket | | |
| EG28-095 | Latch Bracket and Nut | | |
| EG28-103 | Complete Inner Door with Glass | | |



EG28 GAS TRAY AND DOOR ASSEMBLIES
Sept 2003

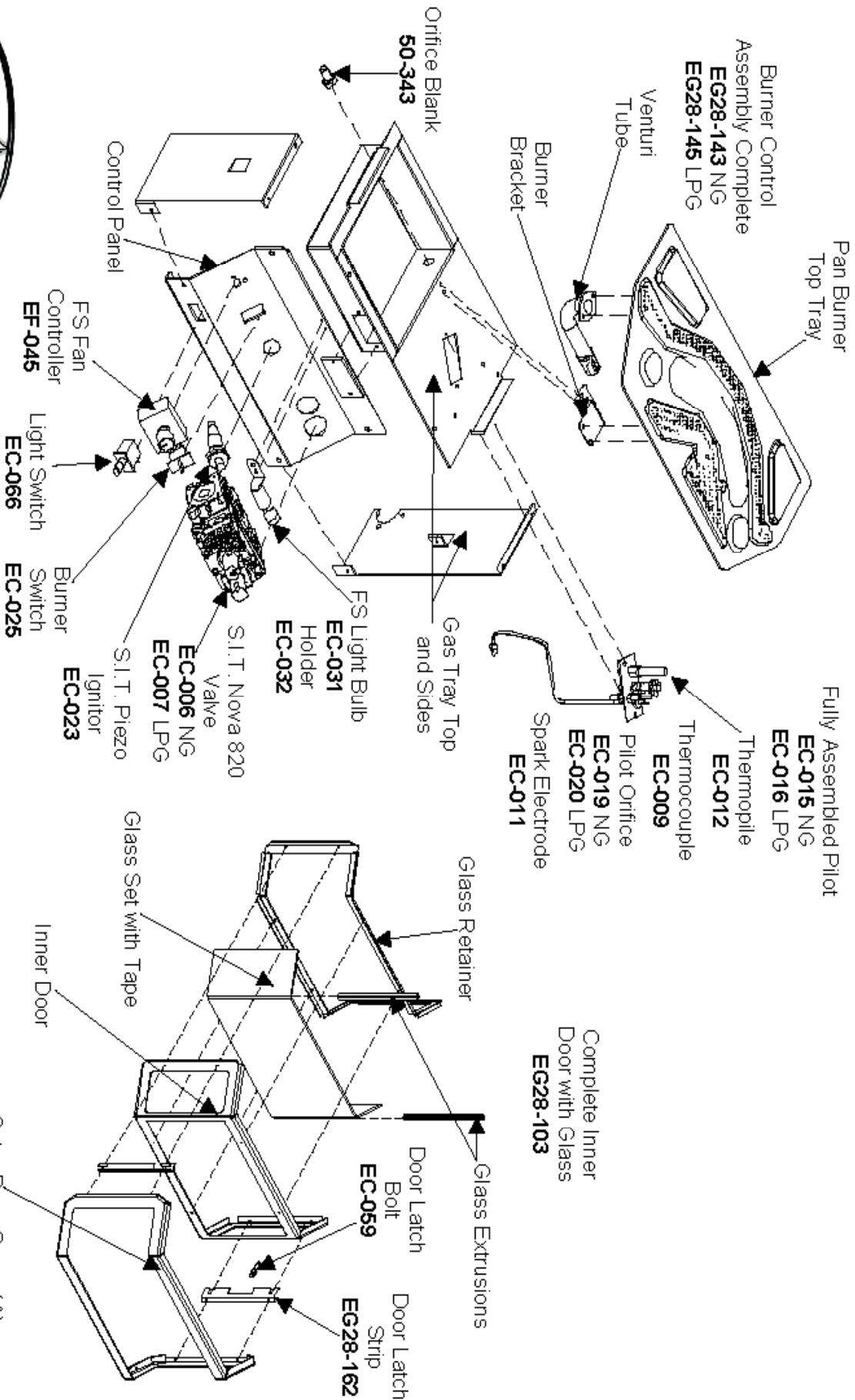

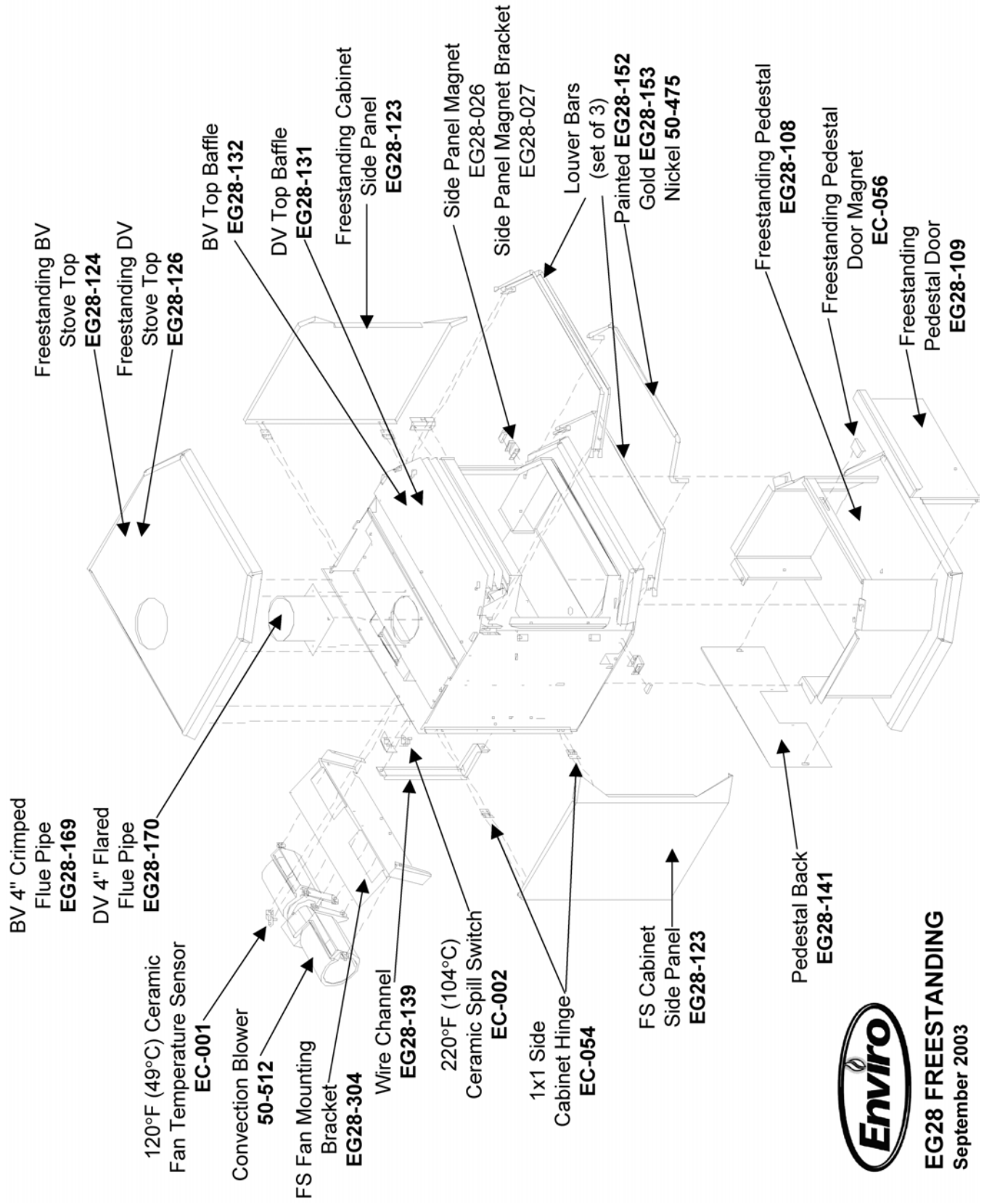

EG28 FREESTANDING
 September 2003

INSTALLATION DATA SHEET

The installer for warranty purposes and future reference must record the following information. Please keep this information for your records.

Model: EG 28 Direct Vent

Name of Owner: _____

Address: _____

Phone: _____

Name of Dealer: _____

Address: _____

Phone: _____

- Model: _____
- Serial Number: _____
- Date of Purchase: _____ / _____ / _____
- Date of Installation: _____ / _____ / _____
- ___ Natural Gas (Nat.), ___ Propane (LPG)
- Inlet Gas Supply Pressure: _____ in.w.c.

If the orifices were changed by the installer.

- Main Orifice: _____
- Pilot Orifice # _____ or _____ in.Dia.

Installer's Signature: _____

Name of Installer: _____

Address: _____

Phone _____

WEBSITE ADDRESS:(www.envirofire.biz)

MANUFACTURED BY:
SHERWOOD INDUSTRIES, 6782 OLDFIELD ROAD, SAANICHTON, B.C., CANADA V8M 2A3

September 18, 2003
C-10109