



WARRANTY REGISTRATION
enviro.com/warranty

Cabello 1200 FPI & Cabello 1700 FPI

WOOD STOVE INSERT

OWNER'S MANUAL



PLEASE READ THIS ENTIRE MANUAL BEFORE INSTALLATION AND USE OF THIS WOOD BURNING ROOM HEATER. FAILURE TO FOLLOW THESE INSTRUCTIONS COULD RESULT IN PROPERTY DAMAGE, BODILY HARM, OR EVEN DEATH.

CONTACT YOUR BUILDING OR FIRE OFFICIALS ABOUT RESTRICTIONS AND INSTALLATION INSPECTION REQUIREMENTS IN YOU AREA.

THIS HEATER MEETS THE 2015 U. S. ENVIRONMENTAL PROTECTION AGENCY'S CRIB-WOOD EMISSION LIMITS FOR WOOD HEATERS SOLD AFTER MAY 15, 2015. UNDER SPECIFIC CONDITIONS THIS HEATER HAS BEEN SHOWN TO DELIVER HEAT AT RATES RANGING FROM 11,479 TO 34,196 BTU PER HOUR FOR THE 1200 AND FROM 9,425 TO 31,780 BTU PER HOUR FOR THE 1700. THESE STOVES HAVE BEEN CERTIFICATION TESTED TO STANDARDS UL-1482-11 AND ULC-S627-00. CERTIFICATION TESTING COMPLETED BY OMNI-TEST LABORATORIES.



OMNI-Test Laboratories, Inc.
Report # 268-S-05-2, 268-S-06c-2

INSTALLER: LEAVE THIS MANUAL WITH THE WOOD STOVE.

CONSUMER: RETAIN THIS MANUAL FOR FUTURE REFERENCE.

Fr Version Française: www.enviro.com/fr.html

50-2627

TABLE OF CONTENTS

Safety Precautions.....	3
Emissions and Efficiency.....	4
Operating Instructions.....	5
Building Your Fire.....	6
How It Works.....	10
Specifications.....	11
Air Control.....	11
General Specifications.....	11
Clearances To Combustibles - 1200-C Insert.....	12
Clearances To Combustibles - 1700-C Insert.....	13
Dimensions - 1200-C Insert.....	14
Dimensions - 1700-C Insert.....	15
Installation.....	16
Removal From Pallet.....	16
Modifications For Installation with 19 ¹ / ₁₆ " (484mm) High Lintel.....	16
Masonry Fireplace Installation.....	17
Surround Panel Sealed Installation for USA Only.....	19
Installation Using A Block-Off Plate For USA Only.....	20
Model 1200-C Brick Placement & Tube Locations.....	22
Model 1700-C Brick Placement & Tube Locations.....	23
C-Cast Ceramic Baffle Installation.....	24
Fan Wiring Diagrams.....	25
Disassembly.....	26
Removal of Cast Top.....	26
Removal of Cast Door.....	26
Removal of Cast Side Panels.....	27
Removal of Cast Bottom.....	27
Removal of Cast Side Bracket.....	28
Removal of Fan Assembly.....	27
Door Latch Adjustment.....	28
Parts Diagram.....	30
Parts List.....	31
Rating Label.....	32
Electrical shock Label.....	33
Notes.....	34
Warranty.....	35
Installation Data Sheet.....	36

Thank you for purchasing your Enviro Fireplace.

SAFETY PRECAUTIONS

FOR SAFE INSTALLATION AND OPERATION OF YOUR “ENVIRO” WOOD STOVE, PLEASE CAREFULLY READ THE FOLLOWING INFORMATION:

- **Please read this entire manual before you install and use your new wood stove. Failure to follow instructions may result in property damage, bodily injury or even death. Be aware that local Codes and Regulations may override some items in this manual. Check with your local inspector.**
- If this appliance is not properly installed, operated and maintained, a serious house fire could result. Makeshift compromises during installation are prohibited and could also result in a serious house fire.
- **HOT WHILE IN OPERATION. KEEP CHILDREN, CLOTHING, AND FURNITURE AWAY. CONTACT MAY CAUSE SKIN BURNS.**
- Operate only with the door tightly closed and burn wood directly on the stove hearth. Do not operate if the door glass is broken or a gasket is missing or damaged. Do not alter the combustion air control valves. Dangerous over-firing could occur which could ignite creosote in the chimney or cause a house fire.
- There needs to be an opening of at least 12 square inches (77.4 cm²) to allow fresh air into the room.
- Do not burn coal or charcoal as there is danger of carbon monoxide being produced. **DO NOT USE CHEMICAL FLUIDS TO START OR RE-FRESH THE FIRE. DO NOT BURN GARBAGE OR FLAMMABLE FLUIDS SUCH AS GASOLINE, GREASE, NAPHTHA OR ENGINE OIL.** Never let the stove become hot enough to get any part red or glowing red.
- Never store gasoline or other flammable liquids near the stove.
- Burning wet, unseasoned wood could cause excessive creosote accumulation in the flue pipe. When ignited, it could cause a chimney fire that could result in a serious house fire.
- Do not use grates, irons or any other methods to support or raise the fire up off the hearth of the appliance.
- This appliance is tested to ULC-S628-93 Standard for Fireplace Inserts, & UL 1482 Standard for Safety for Solid-Fuel Type Room Heaters.
- Both the 1200-C & 1700-C Fireplace Inserts are approved for installation into a zero-clearance fireplace in the USA. In Canada refer to local building or fire officials for restrictions and installation inspection
- A chimney connector shall not pass through an attic, roof space, floor, ceiling, closet or similar concealed space.
- Where passage through a wall, or partition of combustible construction is desired, the installation shall conform to CAN/CSA-B365.
- In the event of component failure, only manufacturer specified replacement parts may be used.
- **DO NOT CONNECT TO ANY AIR DISTRIBUTION DUCT OR SYSTEM.**
- **DO NOT CONNECT THIS UNIT TO A CHIMNEY FLUE SERVING ANOTHER APPLIANCE.**
- **DO NOT INSTALL IN A MOBILE HOME.**



EMISSIONS AND EFFICIENCIES

EMISSIONS AND EFFICIENCY - 1200-C INSERT:

CABELLO 1200

Rates: This manual describes the installation and operation of the Enviro Cabello 1200 wood heater. This heater meets the 2015 U.S. Environmental Protection Agency's wood emission limits for wood emission limits sold after May 15, 2015. Under specific test conditions this heater has been shown to deliver heat at rates ranging from 11,500-34,000 Btu/hr.

Efficiency: 71.6%

EMISSIONS AND EFFICIENCY - 1700-C INSERT:

CABELLO 1700

Rates: This manual describes the installation and operation of the Cabello 1200 wood heater. This heater meets the 2015 U.S. Environmental Protection Agency's wood emission limits for wood emission limits sold after May 15, 2015. Under specific test conditions this heater has been shown to deliver heat at rates ranging from 9,400-32,000 Btu/hr.

Efficiency: 75%

Stress Lines:

Stress lines located within the firebox at the secondary air channels may result from the repeated expansion and contraction of metal during regular use. These lines, when narrower than the thickness of a coin, do not compromise the safety or efficiency of the unit and as such do not necessitate repair or replacement.

Similarly, stress lines that may appear on the firebox front due to regular use also do not compromise safety or efficiency of the unit, with the possible exception of the door gasket. In the event that these extend beyond the door gasket, they may have a minor effect on the integrity of the seal and will then be covered by the warranty policy for repair.

WARNING: This wood heater needs periodic inspection and repair for proper operation. It is against federal regulations to operate this wood heater in a manner inconsistent with operating instructions in this manual.

WARNING: This wood heater has a manufacturer set minimum low burn rate that must not be altered. It is against federal regulations to alter this setting or otherwise operate this wood heater in a manner inconsistent with operating instructions in this manual.

OPERATING INSTRUCTIONS

FIRST START

When first installed, the chimney, firebricks and steel are cold and it usually takes several hours on a fairly high burn for them to become hot and dry enough for the stove to function properly. We recommend during the unit's first burn that a door or window are opened to vent the smoke and fumes created from the unit's paint curing. The paint will smell a little for the first burn or two as it cures.

DISPOSAL OF ASHES:

If you let the ashes accumulate two or three inches at the bottom of the firebox they tend to burn themselves up. Wait until the fireplace has completely cooled before removing ashes. Ashes should be placed in a metal container with a tight fitting lid. The closed container of ashes should be placed on a noncombustible floor or on the ground, well away from all combustible materials, pending final disposal. If the ashes are disposed of by burial in soil or otherwise locally disposed, they should be retained in the closed container until all cinders have thoroughly cooled. Other waste shall not be placed in this container.

FAN OPERATION:

All models have been approved for operation with the manufacturer supplied fan. On medium or high burns, using a fan will increase the heat transfer slightly. Route the electrical cord along the floor in front of the surround panel. There are cutouts in the castings to tuck the cord under.

1. Plug the fan power cord into a standard three (3) prong grounded electrical receptacle.
2. The fan has three modes of operation manual, off, and auto. Fan modes are controlled by a three position switch located on the lower left side of the unit. See wiring diagram for clarification.
3. The fan is controlled by a rotary dial located at the lower left side of the unit. The dial rotation is as follows: OFF>HIGH>LOW
4. If the dial is in any position other than off and is switched to auto mode, the fan will automatically turn on once the stove has reached operating temperature (roughly 25 minutes from a cold start). When the unit cools down, the fan temperature sensor will shut the fan off automatically if in auto mode. The fan can also be turned off manually at any time by rotating the dial to the off position or by setting the switch to the off position. Manual mode will turn on the fan instantly if the dial is not in the off position.

REPLACING THE GLASS:

Never strike or slam the door, hit the glass or let burning wood rest against it as this may cause the glass to crack and cause possible injury. If the glass cracks when the fire is burning, do not open the door until the fire is out and do not operate the stove again until the glass has been replaced. If the glass is damaged in any way, a factory replacement is required (see "PARTS LIST"). To replace the glass, remove the steel retaining clips and all loose glass. Replace only with Neoceram 5 mm glass 16.61" (422 mm) x 10.63" (270 mm) and wrap the edges with 0.125" (3.2 mm) x 0.5" (13 mm) self-adhesive fiberglass gasket.

Wear gloves when handling damaged glass door assembly to prevent personal injury. When the glass door assembly is being transported, it must be wrapped in newsprint and tape and/or a strong plastic bag. **The glass must be purchased from an ENVIRO dealer. No substitute materials are allowed.**

FIRE EXTINGUISHER AND SMOKE DETECTION:

All homes with a wood burning stove should have at least one fire extinguisher in a central location known to all in the household. Smoke detectors and carbon monoxide detectors should be installed and maintained in the room containing the stove. If it sounds the alarm, correct the cause but do not deactivate. You may choose to relocate the smoke detection devise within the room; **DO NOT REMOVE THE SMOKE OR CARBON MONOXIDE DETECTORS FROM THE ROOM.**

OPERATING INSTRUCTIONS

CREOSOTE - ITS FORMATION AND NEED FOR REMOVAL:

When wood is burned slowly, it may produce tar and other organic vapors, which combine with expelled moisture to form creosote. The creosote vapors condense in the relatively cool chimney of a slow-burning fire. As a result, creosote residue accumulates on the flue lining. When ignited this creosote makes an extremely hot fire. The chimney connector and chimney should be inspected biweekly during the heating season to determine if a creosote buildup has occurred. If creosote has accumulated (3mm or more) it should be removed to reduce the risk of a chimney fire.

MAINTENANCE:

At the end of each heating season clean the chimney and the smoke pipe. If soot has accumulated above the top baffle bricks, remove, clean, and then replace them. If a secondary air tube is badly corroded, replace it. Replace worn door gaskets and broken bricks as needed.

FAILURE TO INSPECT AND CLEAN YOUR CHIMNEY SYSTEM REGULARLY CAN RESULT IN A CHIMNEY FIRE, WHICH COULD DAMAGE THE CHIMNEY OR CAUSE A HOUSE FIRE.

CHIMNEY OR RUN AWAY FIRE:

1. Call local fire department (or dial 911)
2. Close the draft fully
3. Examine the flue pipes, chimney, attic, and roof of the house, to see if any part has become hot enough to catch fire. If necessary, spray with fire extinguisher or water from the garden hose.
4. Do not operate the stove again until you are certain the chimney and its lining have not been damaged.

BUILDING YOUR FIRE:

Proper operation of your stove will help to ensure safe, efficient heating. Please take a few moments to review these simple operating procedures.

IMPORTANT: Please be aware when loading your stove that the air tubes in the rear are lower.

1. Fuel Selection:

This stove is designed to burn natural wood only. Higher efficiencies and lower emissions generally result when burning air-dried seasoned hardwoods, as compared to softwoods or too green or freshly cut hardwoods. DO NOT BURN the following: treated wood, coal, garbage, solvents, colored papers or trash. Burning these may result in the release of toxic fumes and may poison or render the secondary air tubes ineffective. Burning coal, cardboard or loose paper can produce soot, or large flakes of char or fly ash that can coat the combustor, causing smoke spillage into the room, and rendering the combustor ineffective.

2. Building/Maintaining a Fire:

- a) Open the primary air slide by pulling it all the way to the right.
- b) Place a base of crumpled uncolored newspaper in the bottom of the stove. Lay pieces of kindling on top of the newspaper and light it.

CAUTION: "Never use gasoline, gasoline-type lantern fuel, kerosene, charcoal lighter fluid, or similar liquids to start or "freshen up" a fire in this heater. Keep all such liquids well away from heater while it is in use.

- c) As the kindling begins to burn, add several larger pieces of wood until the fire is burning well. At this point, regular size logs may be added.

OPERATING INSTRUCTIONS

NOTE: Until the fire is burning well, leave the air controls fully open.

- d) Regulate the heat output of the stove by adjusting the air controls to allow a larger fire and vice versa. A short period of experimentation with the control settings will allow you to regulate the heat output to keep your home comfortable.

Do not use a grate or elevate the fire. Build wood fire on the stove firebox hearth floor.

3. Refueling the Stove:

Use a long pair of gloves (barbecue gloves) when feeding the fire because these stoves burn at the front. They are clean and efficient but they are also very hot and gloves are useful. Keep a small steel shovel and whisk nearby for moving a log or lifting a fallen ember and for keeping the hearth clean.

a) Before attempting to add fuel to the stove, OPEN the damper control fully by pulling it all the way out. This allows the chimney to carry away the additional smoke, which occurs when the door is open.

b) **DO NOT OVERLOAD THE STOVE.** Normally, three or four logs will provide heat for several hours. Never operate this stove where portions glow red hot. Using more than five logs at a time can cause overfiring. Keep logs a few inches from the lowest point of the top of the firebox. If any logs are touching the tubes in the top of the firebox, you can damage the air tubes. Overloading the stove can cause damage to the firebox and air tubes and will void the warranty.

c) **DO NOT OVERFIRE.** If the heater or chimney connector glows, you are overfiring. If the stove top temperatures exceed 550°F, you are overfiring. Overfiring your stove will void the warranty.

d) **WHAT IS OVERFIRING?** Overfiring is when the stove is generating too much heat in the firebox, causing parts within your stove to glow red and warp. To spot overfiring, place a thermometer on the stove top. If the stove top temperatures exceed 550°F, you are overfiring. Another way to spot overfiring is if the heater or chimney connector glows.

e) **CAUTION:** DO NOT PLACE FUEL OR COMBUSTIBLE MATERIAL WITHIN SPACE HEATER INSTALLATION CLEARANCES OR WITHIN THE SPACE REQUIRED FOR CHARGING AND ASH REMOVAL. LOGS SHOULD BE KEPT IN A BIN OR CONTAINER TO REDUCE THE RISK OF LOGS ROLLING INTO THE UNIT'S CLEARANCES.

f) **HOW TO AVOID OVERFIRING:** To avoid overfiring, do not overfill your firebox. Usually a maximum of four logs at a time is sufficient enough to avoid overfiring. Keeping stove top temperatures under 550°F will also prevent overfiring.

g) **KEEP THE ASH LIP CLEAR OF EMBERS AND ASH.** If the door is closed with debris in the way, the door gasket seal could be compromised.

4. For Maximum Efficiency:

When the stove is hot, load it fully to the top of the door opening and burn at medium low settings. When the fuel is mostly consumed, leaving a bed of red coals, repeat the process. Maximum heat for minimum fuel occurs when the stove top temperature is between 250°F (120°C) and 550°F (290°C). The most likely causes of dirty glass are: not enough fuel to get the stove thoroughly hot, burning green or wet wood, closing the draft until there is insufficient air for complete combustion, or a weak chimney draw. Indeed, the cleanliness of the glass is a good indicator of the stove operating efficiently.

Helpful Hints Worth Repeating

1. Helpful advice on the correct way to start your fire.

- a) You will need small pieces of dry wood, called kindling, and paper. Use only newspaper or paper that has not been coated or had other materials glued or applied to it. Never use coated (typically advertising flyers) or coloured paper.

OPERATING INSTRUCTIONS

- b) Always open the door of the wood stove slowly to prevent suction and drawing smoke into the room.
- c) Crumple several pieces of paper and place them in the center of the firebox, directly on top of the firebricks in the wood stove. Never use a grate to elevate the fire.
- d) Place small pieces of dry wood (kindling) over the paper in a "teepee" manner. This allows for good air circulation, which is critical for good combustion.
- e) Light the crumpled paper in 2 or 3 locations. Note: It is important to heat the air in the stovepipe for draft to start.
- f) Fully open the air controls of the wood stove and close the door until it is slightly open, allowing for much needed air to be introduced into the firebox. Never leave the door fully open, as sparks from the kindling may fly out of the stove, causing damage or injury. As the fire begins to burn the kindling, some additional kindling may be needed to sustain the fire. DO NOT add more paper after the fire has started.
- g) Once the kindling has started to burn, add some smaller pieces of seasoned, dry firewood. Note: Adding large pieces at the early stages will only serve to smother the fire. Continue adding small pieces of seasoned dry firewood, keeping the door slightly open until each piece starts to ignite. Remember to always open the door slowly between placing wood into the fire.
- h) Once the wood has started to ignite and the smoke has reduced, close the wood stove door fully. The reduction of smoke is a good indication that the draft in the chimney has started to heat up and good combustion is now possible. Larger pieces of seasoned, dry firewood can now be added when there is sufficient space in the firebox. Adjust the air control setting to desired setting. Note: The lower the air control setting, the longer the burn time of your firewood.

2. What type of wood is best to use as firewood?

Both hardwood and softwood burn well in this stove. Both woods contain about 8,000 BTU/lb (18,570 KJ/Kg), but hardwood is generally more dense, will weigh more per cord, and burns a little slower and longer. Cutting firewood so that it will fit horizontally, front to back, makes it easier loading and less likely for the fuel to roll on the glass. Except for a cold start, there is no need to crisis-cross the logs. Ideal length for the logs used in the 1200-C would be about 16" (381 mm) but it can burn pieces up to 18" long. Ideal length for the logs used in the 1700-C would be about 18" (381 mm) but it can burn pieces up to 20" long logs. Burn only dry, seasoned wood. It produces more heat and less soot or creosote. Freshly cut wood has about 50% moisture. A 10 pound (4.5 Kg) log contains 5 pounds (2.3 Kg) of water. To season firewood, split and stack it so that air can get to all parts of the wood. Burn beach wood only if its salt content has been washed away in a season of rain and then the wood dried. To prevent smoke spillage when refueling, fully open the damper and open the door slowly.

3. What does dry, seasoned wood mean?

Wood that has been dried for a period of one year in a well-ventilated and sheltered area would be considered dry, seasoned wood. Wood from slow-growing trees is generally considered better than wood from fast-growing trees. To season firewood, split and stack it so that air can get to all parts of the wood.

4. Will following the above-listed steps for starting a fire mean perfect results every time?

The quick answer is 'most of the time'. There are many variables that may affect your success when starting a fire. Most of those variables and how to deal with them will be learned through experience. Your ability to start a good fire will significantly increase with time and patience. Some of the reasons for poor stove performance will be covered in the next section of these instructions.

OPERATING INSTRUCTIONS

5. Why can't I get the fire lit?

Damp or wet wood and poor drafts are the main reasons for poor results in starting a fire. Always use dry, seasoned wood for your fire. Even wood dried for two years will be difficult to ignite if it has become wet.

6. Is it normal for soot to cover the glass at the beginning of a fire?

Your stove has been built with an air-wash system that will help keep the glass clear when the firebox has reached a good operating temperature and has a good draft. Normally, a hot stove will keep the glass clean, but if you must clean the glass, use a soft cloth with no abrasive and clean only when the unit is cold. Cold firebox temperature and poor draft cause sooting of the glass. Once the firebox temperature and the draft increase, the soot will burn off.

7. What is draft?

Draft is the ability of the chimney to exhaust or draw smoke produced during the normal combustion process. Too much draft may cause excessive temperatures in the appliance and may damage the appliance. Inadequate draft may cause backpuffing or "plugging" of the chimney. There is a certain amount of draft that is required to allow for your stove to function at its' highest efficiency. A water column gauge can be used to reference this amount.

8. What can cause a poor draft?

The most common factors for poor draft are:

- a) Air supply
 - b) Environmental conditions
 - c) Cold chimney temperature
 - d) Poor chimney installation and maintenance
 - e) Atmospheric pressure
-
- a) Air supply – Inside the home, normal household appliances such as clothes dryers and forced-air furnaces compete for air, resulting in air starvation to the fire. This creates a condition in the house known as negative pressure. When a house experiences negative pressure, the combustion gases can be drawn from the chimney and into the house. This condition is commonly referred to as down-drafting. Increased amounts of insulation, vinyl windows, extra caulking in various places and door seals can all keep heat in but may also make a home too airtight. An easy way to stop negative pressure in a home is to crack a window in the room containing the stove.
 - b) Environmental Conditions - High trees, low-lying house location such as in a valley, tall buildings or structures surrounding your house and windy conditions can cause poor draft or down-drafting.
 - c) Cold Chimney Temperature - Avoid cold chimney temperatures by burning a hot fire for the first fifteen to forty minutes, being careful not to over-fire the stove. If any part of the chimney or parts of the stove start to glow, you are over-firing the stove. Where possible, install a temperature gauge on the chimney so temperature drops can be seen.
 - d) Chimney Installation and Maintenance - Avoid using too many elbows or long horizontal runs. If a chimney run is too short this can cause difficult start-up, dirty glass, back smoking when door is open, and even reduced heat output. Too tall a chimney may prompt excessive draft, which can result in very short burn times and excessive heat output. If in doubt, contact a chimney expert and/or chimney manufacturer for help. To prevent creosote build up clean the chimney, rain cap, and spark arrestor regularly.

9. How can you reduce visible emissions?

If all of these steps are followed, there should be no visible emissions.

Note: These instructions are intended as an aid and do not supercede any local, provincial or state requirements. Check with officials or authorities having jurisdiction in your area.

OPERATING INSTRUCTIONS

How it Works :

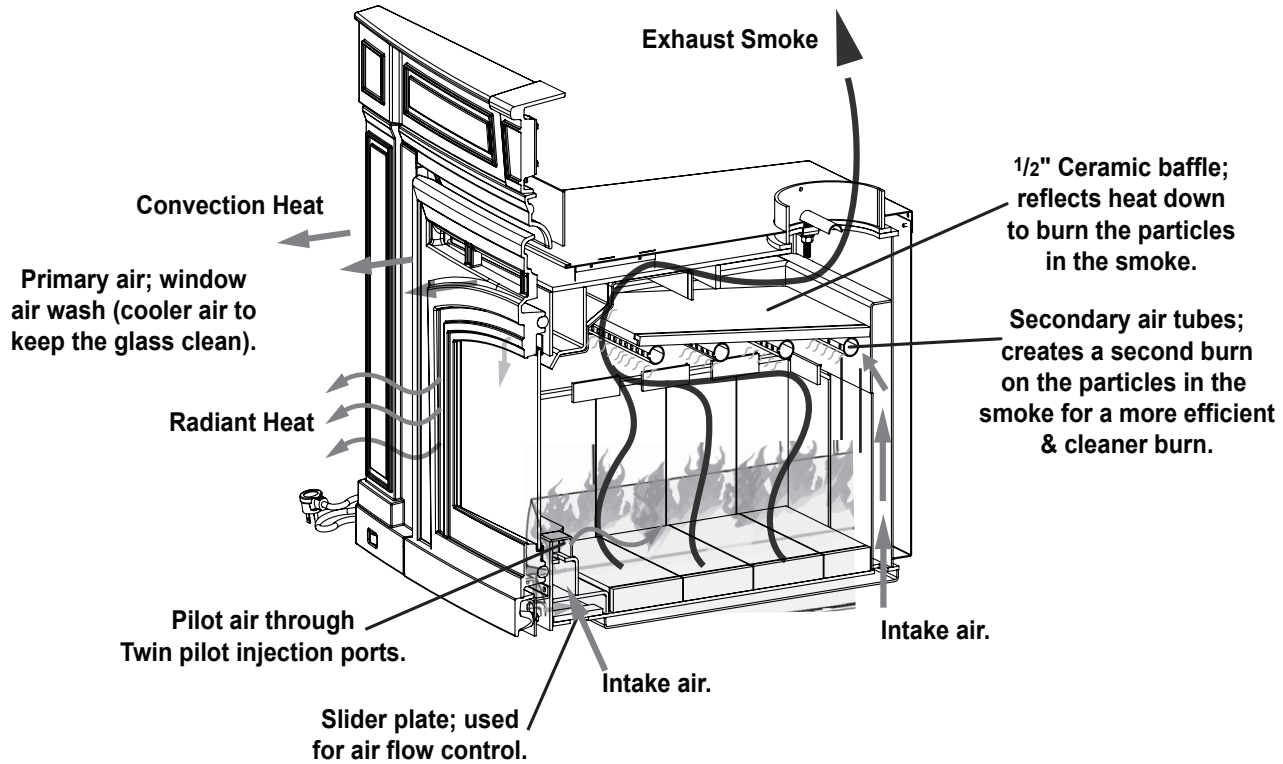

Figure 1: 1200-C Air Flow Path.

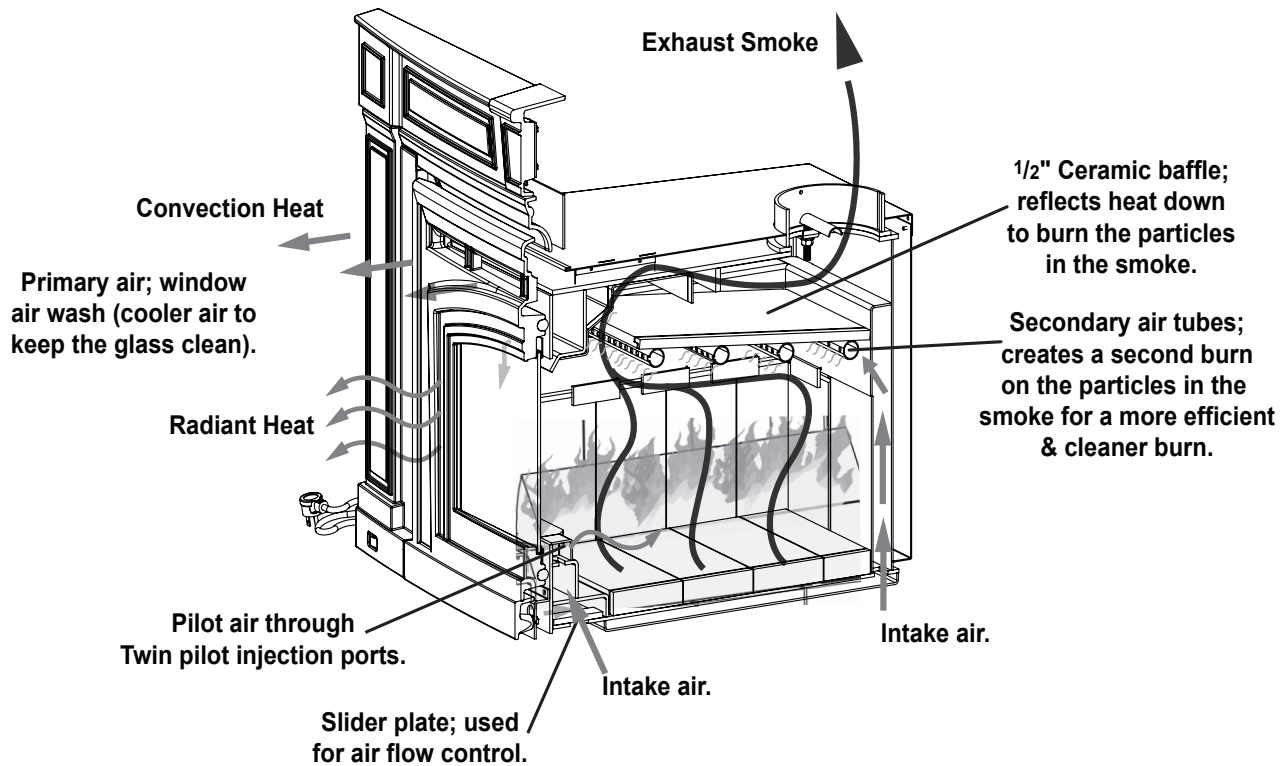

Figure 2: 1700-C Air Flow Path.

SPECIFICATIONS

AIR CONTROL:

The primary air is controlled by the rod located on the right side of the unit. To increase your air, pull the rod out and to decrease, push the rod in. All the units have a secondary air that flows through the tubes at the top of the firebox, just below the baffles.

Pull this control all the way out when first starting the stove. Once the fire has been established you may adjust this control to set the burn rate of the fire. For optimal efficiency, use a low to medium setting. If this damper is closed at first start-up, the fire will burn very slowly and could soot the appliance.

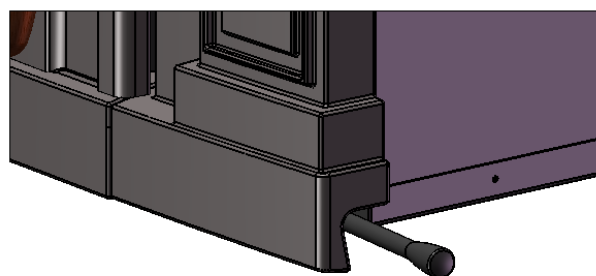

Figure 3: Air Control Rod.

When shutting down the stove, fully open the air control. This allows the chimney temperatures to remain as high as possible for as long as possible. Cold chimney temperatures create creosote.

GENERAL SPECIFICATIONS:

Table 1: 1200-C & 1700-C General Information.

Model	1200 Insert	1700 Insert
Minimum Install Width x Depth	31 ⁵ / ₈ in x 18 ¹ / ₄ in (805 mm x 464 mm)	31 ⁵ / ₈ in x 22 ³ / ₄ in (805 mm x 578 mm)
Install Height of body	19.063 in (486 mm) or 19.563 in (497 mm)	
Interior Fire box size (depth x width x height)	16.10 in x 18.25 in x 11.15 in (409 mm x 464 mm x 283 mm)	20.65 in x 18.25 in x 11.95 in (525 mm x 464 mm x 304 mm)
Firebox Capacity	1.85 ft ³ (0.053 m ³)	2.50 ft ³ (0.071m ³)
Approximate heating area	2200 ft ² (205 m ²)	3000 ft ² (280 m ²)
E.P.A. output rating	11479 - 34196 BTU/hour (3361 - 10013 Watt)	9425 - 31780 BTU/hour (2760 - 9306 Watt)
Duration on low burn	6 -10 hours	8 - 12 hours
Weight with packaging	335 lb (151.95 Kg)	390 lb (176.90 Kg)
E.P.A. Emissions	3.3 grams/hour (0.116 oz/hour)	4.48 grams/hour (0.158 oz/hour)
Cast Surround		
Standard (width x height)	41.125 in x 28.600 in (1045 mm x 727 mm)	
Rating Label Location	Right Side of Unit; behind surround	

SPECIFICATIONS

CLEARANCES TO COMBUSTIBLES - 1200-C INSERT:

Table 2: 1200-C Insert Clearance to Combustibles.

A	Minimum clearance to an unshielded side wall	14 in (254 mm)
B	Minimum clearance to an unshielded 8" (203 mm) mantel	21 in (533 mm)
C	Minimum top facing (protruding ¾" [19 mm]) clearance	17.5 in (445 mm)
D	Minimum side facing (protruding ¾" [19 mm]) clearance	1 in (25 mm)
E	† From front of door opening to edge of floor protection	USA 16 in (406 mm) CND 18 in (450 mm)
F	† From side/back of unit to edge of floor protection	USA 6 in (152 mm) CND 8 in (203 mm)

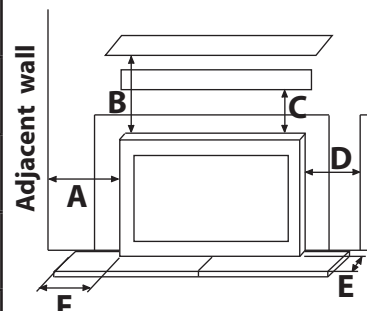

† FLOOR PROTECTION:

If unit is raised 0 - 2 in (0 - 51 mm); 1 in (25 mm) non-combustible material with R value = 0.59 or equivalent.
 If unit is raised 2 - 8 in (51 - 203 mm); 0.5 in (13 mm) non-combustible material with R value = 0.59 or equivalent.
 If unit is raised greater than 8 in (203 mm) or more; any non-combustible material can be used.

Table 3: Reduction in (B) Minimum Clearance from 1200-C to 8" (203 mm) Mantel.

Type of protection	Modified Clearance
A minimum of .013 in (0.33 mm) sheet metal spaced out 1 in (25 mm) by non-combustible spacers.	10.50 in (267 mm)
Ceramic tiles, or equivalent non-combustible material on non-combustible supports and spaced out 1 in (25 mm) by non-combustible spacers.	14.00 in (356 mm)
Ceramic tiles, or equivalent non-combustible material on non-combustible supports with a minimum of .013 in (0.33 mm) sheet metal spaced out 1 in (25 mm) by non-combustible spacers.	10.50 in (267 mm)

NOTES:

- (1) Mantel protection must have at least 3 in (75 mm) edge clearance on all sides, except as provided in Note 4.
- (2) If an adhesive is used to support non-combustible material, it shall not lose adhesive qualities at temperatures likely to be encountered and shall not contribute a significant combustible load.
- (3) Heat shield mounting hardware attached to combustible materials must be placed at the lateral extremities of the shield.
- (4) Minimum clearance to unprotected walls and ceilings must be maintained.
- (5) Clearances may only be reduced with shielding acceptable to the local authority.

Table 4: 1200-C Insert Minimum Fireplace Install Size.

	Masonry	Zero Clearance
Minimum Depth	18¼ in (464 mm)	18¾ in (476 mm)
Minimum Width at back of fireplace	22⅝ in (575 mm)	23 in (584 mm)
Minimum Width at front of fireplace	31⅝ in (805 mm)	32 in (813 mm)
**Minimum Height	19¼ in (489 mm) or 19¾ in (502 mm)	20 in (508 mm)

** If the masonry lintel height is only 19¼ in (489 mm) to 19¾ in (502 mm) refer to INSTALLATION - MODIFICATIONS FOR INSTALLATION WITH 19¼" (489 mm) HIGH LINTEL - INSERT

SPECIFICATIONS

CLEARANCES TO COMBUSTIBLES - 1700-C INSERT:

Table 5: 1700-C Insert Clearance to Combustibles.

A	Minimum clearance to an unshielded side wall	14 in (254 mm)
B	Minimum clearance to an unshielded 8" (203 mm) mantel	24 in (610 mm)
C	Minimum top facing (protruding ¾" [19 mm]) clearance	19.5 in (495 mm)
D	Minimum side facing (protruding ¾" [19 mm]) clearance	1 in (25 mm)
E	† From front of door opening to edge of floor protection	USA 16 in (406 mm) CND 18 in (450 mm)
F	† From side/back of unit to edge of floor protection	USA 6 in (152 mm) CND 8 in (203 mm)

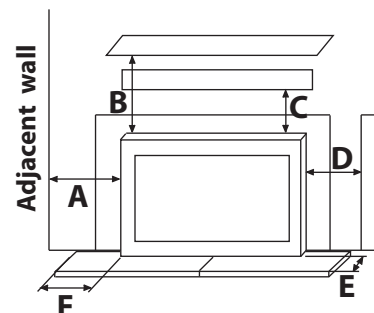

† FLOOR PROTECTION:

If unit is raised 0 - 2 in (0 - 51 mm); 1 in (25 mm) non-combustible material with R value = 0.59 or equivalent.
 If unit is raised 2 - 8 in (51 - 203 mm); 0.5 in (13 mm) non-combustible material with R value = 0.59 or equivalent.
 If unit is raised greater than 8 in (203 mm) or more; any non-combustible material can be used.

Table 6: Reduction in (B) Minimum Clearance from 1700-C to 8" (203 mm) Mantel.

Type of protection	Modified Clearance
A minimum of .013 in (0.33 mm) sheet metal spaced out 1 in (25 mm) by non-combustible spacers.	12.00 in (305 mm)
Ceramic tiles, or equivalent non-combustible material on non-combustible supports and spaced out 1 in (25 mm) by non-combustible spacers.	16.13 in (410 mm)
Ceramic tiles, or equivalent non-combustible material on non-combustible supports with a minimum of .013 in (0.33 mm) sheet metal spaced out 1 in (25 mm) by non-combustible spacers.	12.00 in (305 mm)

NOTES:

- (1) Mantel protection must have at least 3 in (75 mm) edge clearance on all sides, except as provided in Note 4.
- (2) If an adhesive is used to support non-combustible material, it shall not lose adhesive qualities at temperatures likely to be encountered and shall not contribute a significant combustible load.
- (3) Heat shield mounting hardware attached to combustible materials must be placed at the lateral extremities of the shield.
- (4) Minimum clearance to unprotected walls and ceilings must be maintained.
- (5) Clearances can be reduced with shielding acceptable to the local authority.

Table 7: 1700-C Insert Install Fireplace Size.

	Masonry	Zero Clearance
Minimum Depth	22¾ in (578 mm)	23¼ in (591 mm)
Minimum Width at back of fireplace	22⅝ in (575 mm)	23 in (584 mm)
Minimum Width at front of fireplace	31⅝ in (805 mm)	32 in (813 mm)
**Minimum Height	19¼ in (489 mm) or 19¾ in (502 mm)	20 in (508 mm)

** If the masonry lintel height is only 19¼ in (489 mm) to 19¾ in (502 mm) refer to INSTALLATION - MODIFICATIONS FOR INSTALLATION WITH 19¼" (489 MM) HIGH LINTEL - INSERT

SPECIFICATIONS

DIMENSIONS - 1200-C INSERT:

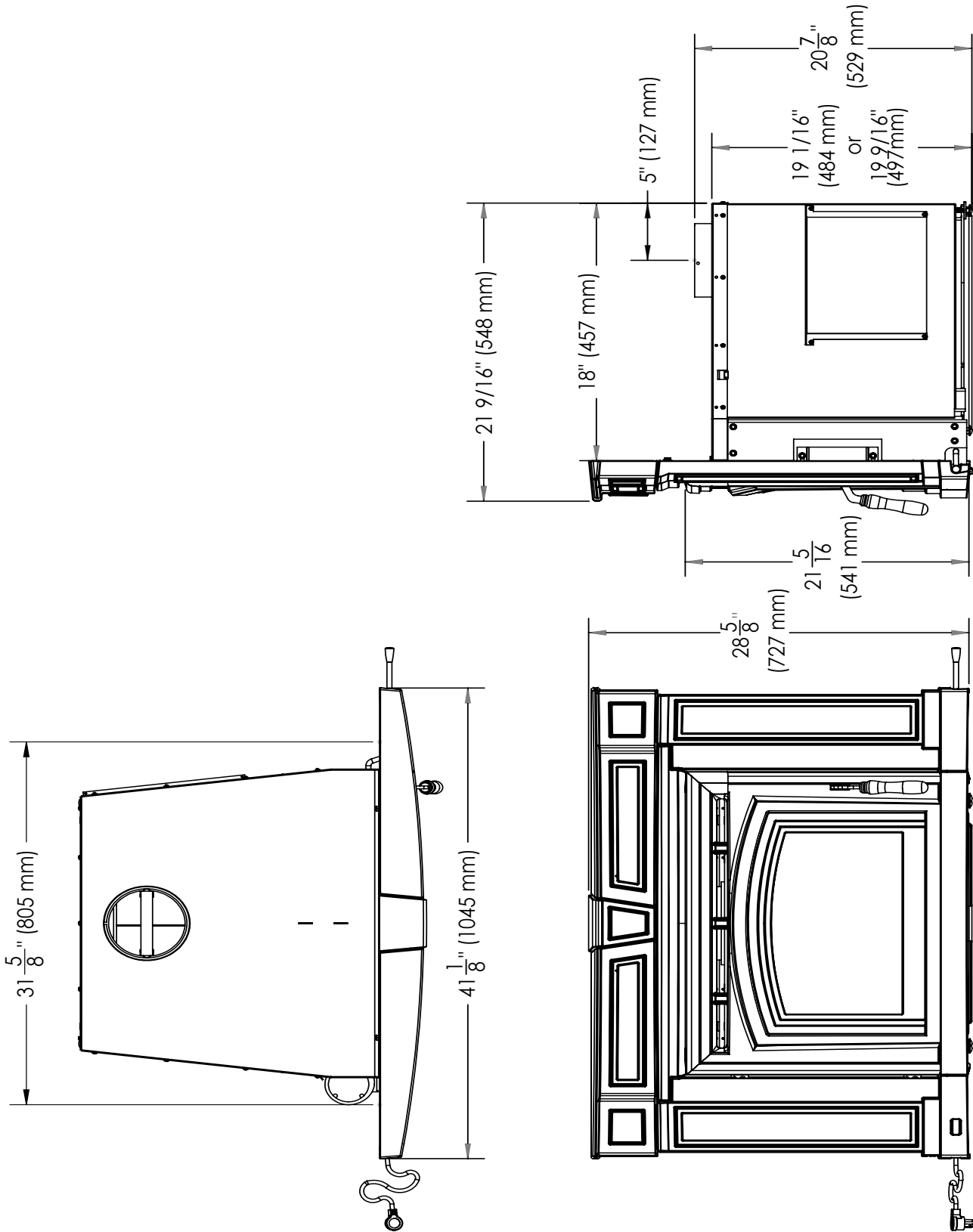

Figure 4: 1200-C Insert Dimensions.

SPECIFICATIONS

DIMENSIONS - 1700-C INSERT:

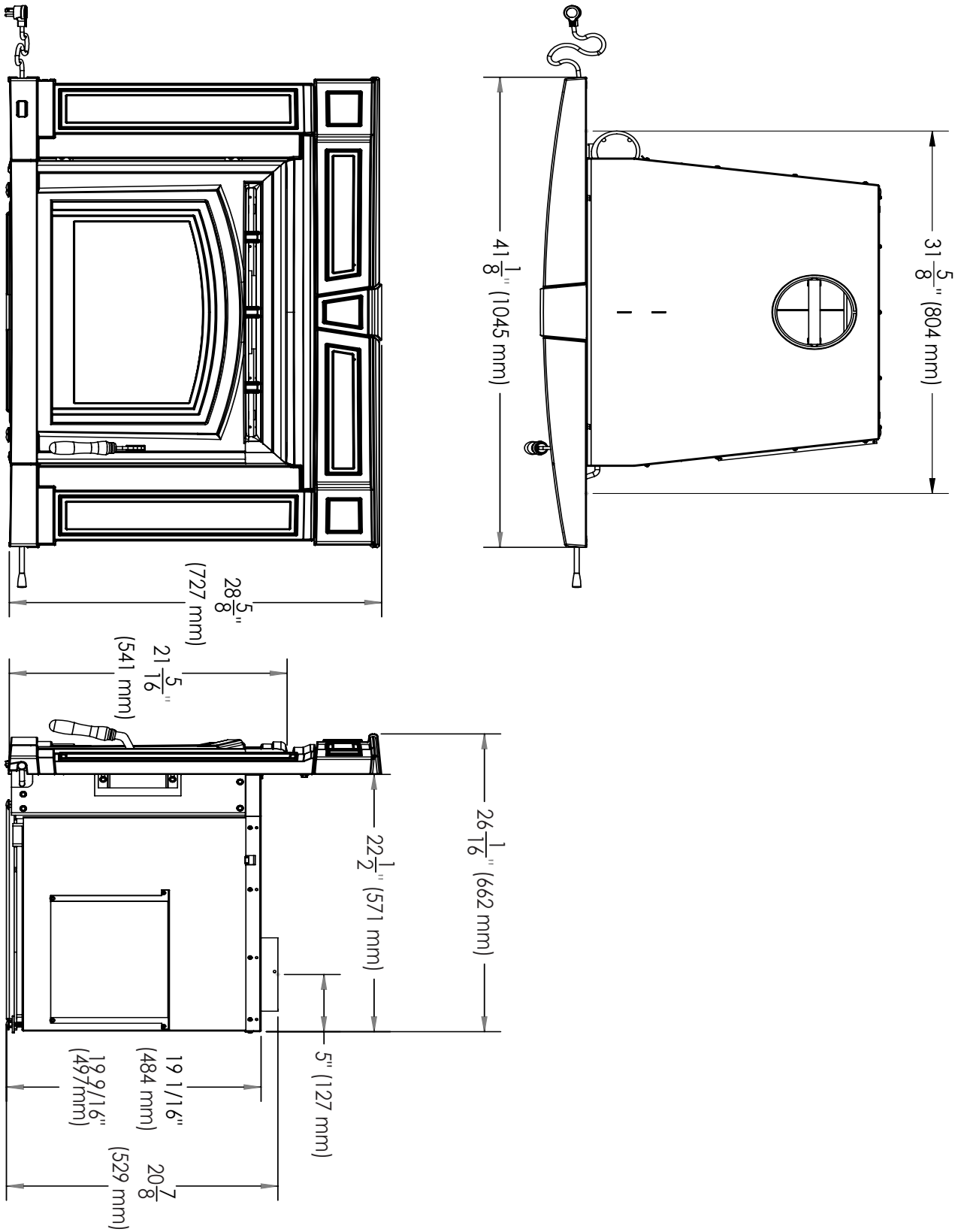

Figure 5: 1700-C Insert Dimensions.

INSTALLATION

Failure to follow these instructions carefully could cause personal injury or property damage.

REMOVAL FROM PALLET

- Remove the bricks from the unit before starting.
- Remove the two lag bolts (shown in Figure 6) that secure the unit to the pallet from inside the firebox.

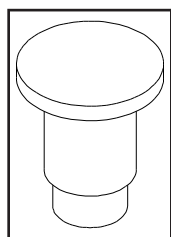

Figure 7:
Rivet.

Note: Before the bricks are re-installed, supplied rivets (Figure 7) must be placed in the holes which the lag bolts were removed from. This is done to seal the unit and make unit burn more efficiently.

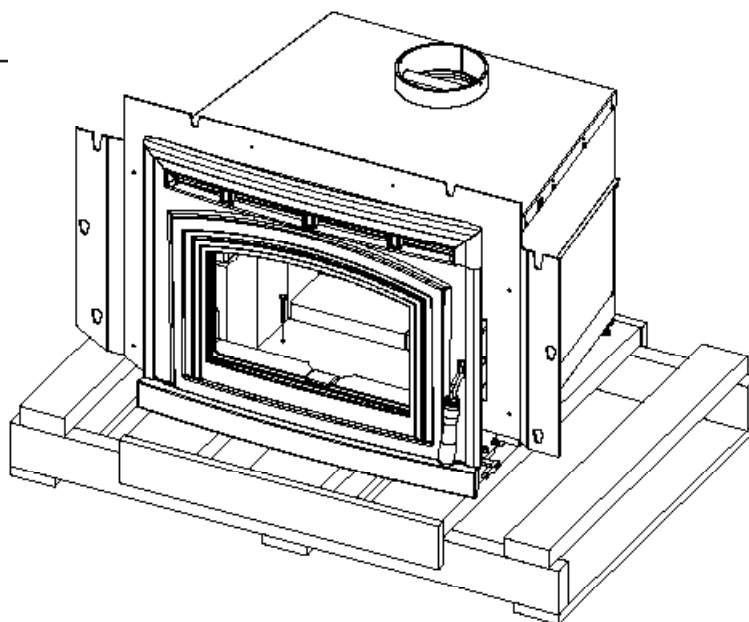

Figure 6: Bolts to remove.

MODIFICATIONS FOR INSTALLATION WITH 19¹/₁₆" (484MM) HIGH LINTEL:

The Cabello has a factory height of 19⁹/₁₆" (497mm) and it can be reduced to 19¹/₁₆" (484mm) by modifying the cabinet top installation.

1. Remove the thirteen T-20 screws holding the cabinet top in place (refer to Figure 8).
2. Remove the cabinet top and flip it onto its top.
3. Remove the Air Deflector (shown in Figure 9) by removing the two (2) T-20 screws.
4. Re-install the cabinet top onto the unit. The screw holes along the top of the unit should now line up with the top set of holes on the cabinet back.

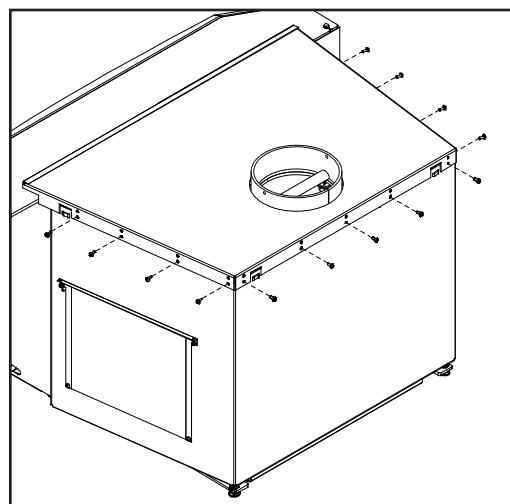

Figure 8: Removing Cabinet Top from Unit.

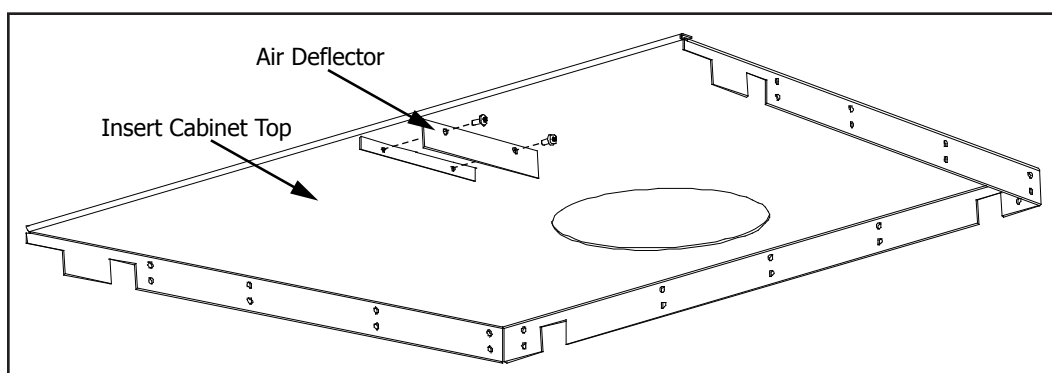

Figure 9: Removing Air Deflector on Cabinet Top.

INSTALLATION

MASONRY FIREPLACE INSTALLATION:

Unless you are experienced, we recommend installation by your dealer or a professional installer.

Install only in a masonry fireplace with a good-condition chimney at least 15 ft (4.6 m) high, both of which have been constructed in accordance with the building code. Refer to Tables 4 and 7 for minimum masonry fireplace dimensions. Be sure the fireplace and chimney are clean and sound without any cracks or loose mortar. Do not remove any bricks or mortar from the fireplace.

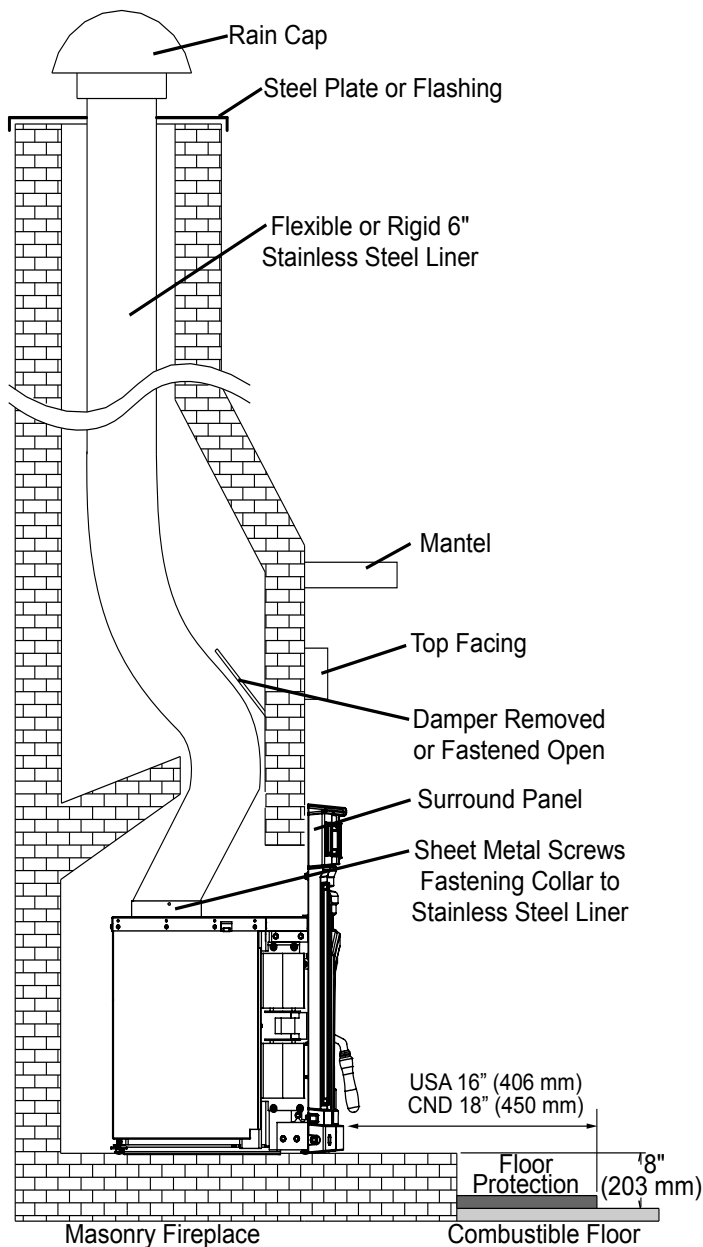

Figure 10: Insert Installation into existing fireplace with hearth.

If there is a combustible floor in front of the masonry fireplace, the fireplace insert must be 8" (203 mm) above the combustible floor, and floor protection must be provided 18" (457 mm) in front of the fireplace insert and 8" (203 mm) to each side of the unit. Refer also to SPECIFICATIONS - CLEARANCES TO COMBUSTIBLES - 1200-C INSERT and SPECIFICATIONS - CLEARANCES TO COMBUSTIBLES - 1700-C INSERT.

1. Remove any fireplace damper or fasten in a permanent open position.

2. (IN CANADA) The stove is vented with a 6" stainless steel liner that goes directly to the top of the chimney and is covered with a rain cap. The chimney top is sealed with a flashing or steel plate that supports the weight of the chimney liner. The installation must conform to the liner's manufacturer's instructions.

This fireplace must be installed with a continuous liner of 6" diameter (CANADA ONLY) extending from the fireplace insert to the top of the chimney. The chimney liner must conform to the Class 3 requirements of CAN/ULC-S635 Standard for Lining Systems for Existing Masonry or Factory-Built Chimneys and Vents, or CAN/ULC-S640 Standard for Lining Systems for New Masonry Chimneys.

(IN U.S.A.) The appliance when installed, must follow local building codes, in the absence of local building codes, with the current NFPA 211 Standard for Chimneys, Fireplaces, Vents, and Solid Fuel-Burning Appliances.

INSTALLATION

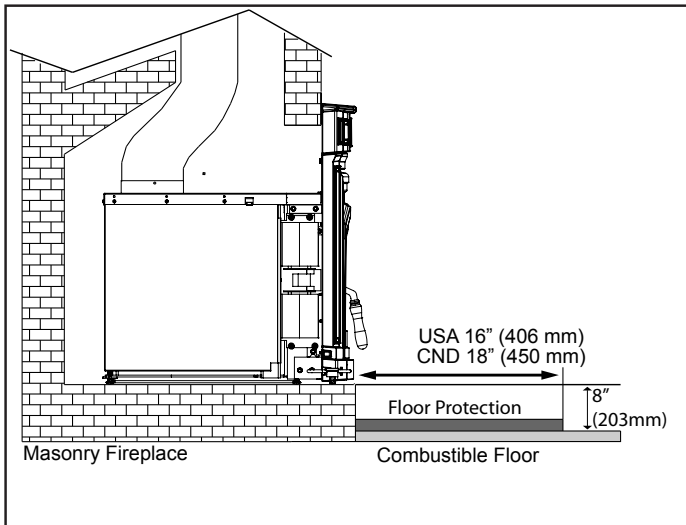

Figure 11: Insert Installation into existing fireplace without hearth.

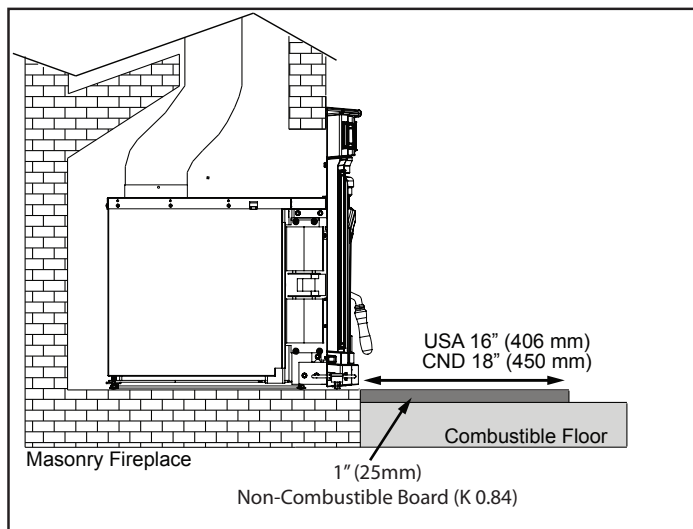

Figure 12: Insert Installation into existing floor level masonry fireplace.

The flue collar is removable for installations into fireplaces with low openings.

A) Remove the rear two (2) secondary air tube and C-Cast Ceramic Baffles, if installed (see C-CAST CERAMIC BAFFLE INSTALLATION). Remove the secondary air tubes by placing a screwdriver (any style except flat head) into one of the air holes and tapping it with a hammer/mallet to the left.

B) Unscrew the two (2) nuts on top of the inside of the firebox, using a $\frac{9}{16}$ \"/>

C) Pull the removable flue collar off the top of the unit.

D) Attach the flue collar to the venting pipe using sheet metal screws.

E) Push the unit into place while trying to keep the collar attached to venting close to the opening on the top of the unit.

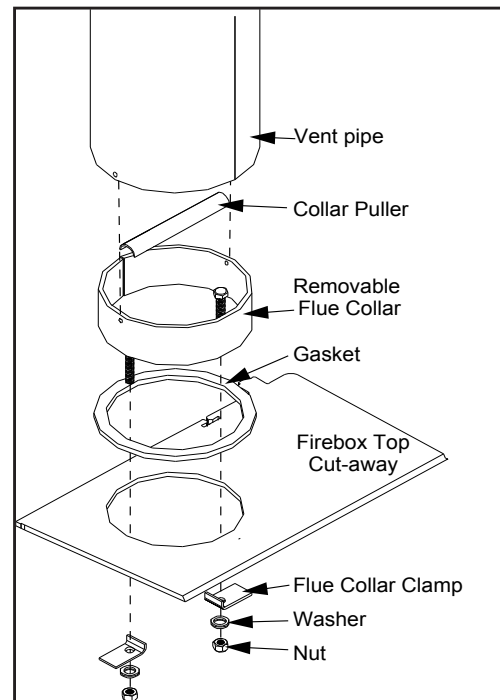

Figure 13: Attaching removable flue collar.

F) Place the Collar Puller, over the two bolts of the Flue Collar and pull it into place (see Figure 14). Ensure that the bolts are to the left and right of the hole. If they are not, the front secondary air tube will need to be removed in order to install or remove the C-Cast Ceramic Baffles.

G) Slide the Flue Collar Clamps and washers over the bolts, and screw the nuts back onto the bolts.

H) Re-install C-Cast Ceramic Baffles and the rear two (2) secondary air tube (see C-CAST CERAMIC BAFFLE INSTALLATION).

INSTALLATION

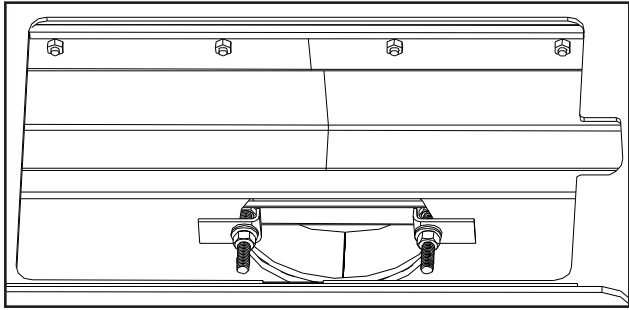

Figure 14: Removable flue collar in place.

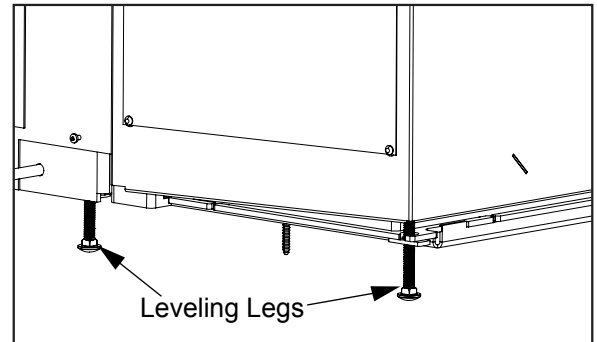

Figure 15: Leveling legs.

3. There are four (4) leveling legs (shown in Figure 15), two (2) on each side, one at the back and one at the front of the unit. Adjust the legs using a $\frac{3}{8}$ " wrench to ensure the unit is stable.
4. Screw or nail the provided metal plate with the wording "THIS FIREPLACE HAS BEEN ALTERED TO ACCOMMODATE A FIREPLACE INSERT AND SHOULD BE INSPECTED BY A QUALIFIED PERSON PRIOR TO THE RE-USE AS A CONVENTIONAL FIREPLACE." To the inside of the fireplace.

SURROUND PANEL SEALED INSTALLATION FOR USA ONLY:

Note: Though this is an allowable installation, we do not recommend it because of the possibility of poor draft, and therefore poor stove performance. Before starting this type of installation refer to INSTALLATION - MASONRY FIREPLACE INSTALLATION - INSERT for additional information. For clearances refer to SPECIFICATIONS - CLEARANCES TO COMBUSTIBLES - 1200-C INSERT and SPECIFICATIONS - CLEARANCES TO COMBUSTIBLES - 1700-C INSERT.

1. Before the face plate is installed onto the unit, glue a 6" (150mm) wide R20 fiberglass insulation strip around the perimeter of the back of the panels using RTV silicon or stove gasket cement. When the face plate is installed onto the unit the insulation must overlap the fireplace opening to form a seal between the masonry fireplace and the unit's face plate. Let the silicon or cement dry.
2. To make the installation of the surround panel onto the unit easy have the unit 6" (150mm) out from the fireplace,
3. Push the insert into the fireplace, allowing the insulation to form a seal between the panels and the fireplace. Tuck any exposed insulation behind the face plate.

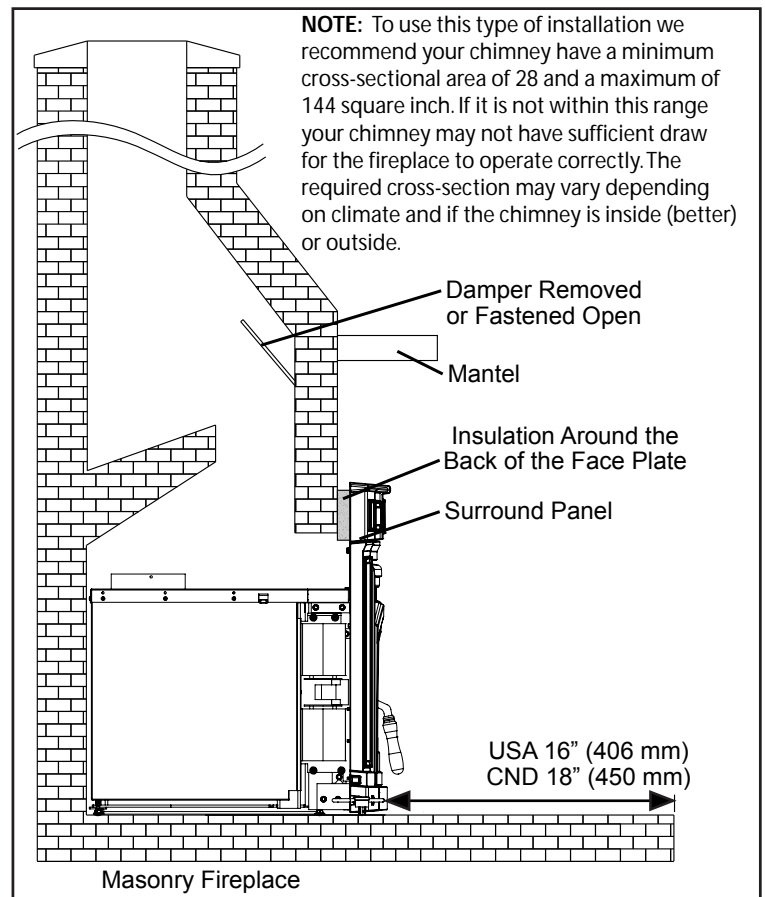

Figure 16: Installation with Surround Sealed.

INSTALLATION

INSTALLATION USING A BLOCK-OFF PLATE FOR USA ONLY:

If this unit is to be installed into a masonry fireplace or a zero-clearance fireplace with a direct connection you must install a non-combustible seal-off device such as a block-off plate or damper adapter. By installing a block-off plate you seal the chimney, ensuring that no smoke enters the home and sealing the chimney to encourage draft. To construct a block-off plate follow the below steps.

Before starting this type of installation refer to **INSTALLATION - MASONRY FIREPLACE INSTALLATION - INSERT** for additional information. For clearances refer to **SPECIFICATIONS - CLEARANCES TO COMBUSTIBLES - 1200-C INSERT** and **SPECIFICATIONS - CLEARANCES TO COMBUSTIBLES - 1700-C INSERT**. See Figure 19 and 20 for examples of a masonry fireplace and a zero-clearance fireplace with a direct connection.

1. Determine where the block-off plate will be installed; above the top of the firebox (it must be high enough to easily install the connection pipe) but below the damper area. Look for a location that is level and in an area where the plate can be mounted easily.

The measurement that will be needed are as followed (refer to Figure 17 and 18):

A - The width at the front of the firebox at the height where the block-off plate will be installed.

B - The width at the back of the firebox at the height where the block-off plate will be installed.

C - Then depth of the block-off needed (the distance between A and B).

D - The distance of the center of the flue to the front of the fireplace opening. Refer to Step 3.

NOTE: In general masonry fireplaces have square fireboxes while zero-clearance (metal) fireplaces have domed firebox tops. Therefore zero-clearance block-off plates may be more difficult to install. Insulation may be used around the edges to simplify sealing the plate.

2. Create a cardboard template of the dimensions with 2" (51 cm) wide flanges on each side. These flanges will be used to mount the block-off plate to the inside of the firebox. Bend the flanges downwards on the template and place it inside the fireplace. Continue on if the template fits correctly in its planned location. If the template does not fit, make a new template with the required corrections until it does fit correctly.
3. With the template in place, mark the location for the center of the flue pipe when the unit is in place. If installing a 1200-C the distance will be approximately 8 $\frac{1}{4}$ " or 9 $\frac{15}{16}$ " back from the fireplace opening. If installing a 1700-C the distance will be approximately 12 $\frac{3}{4}$ " or 14 $\frac{7}{16}$ " back from

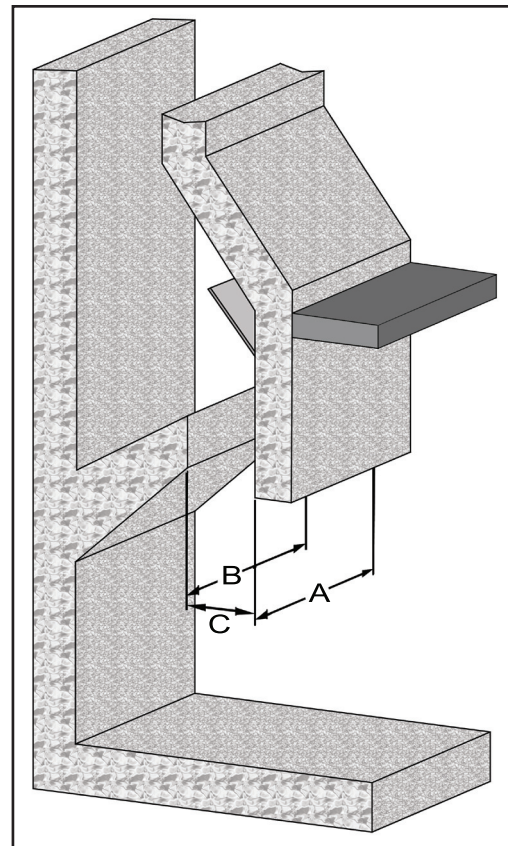

Figure 17: 3D of Dimensions needed from the Fireplace.

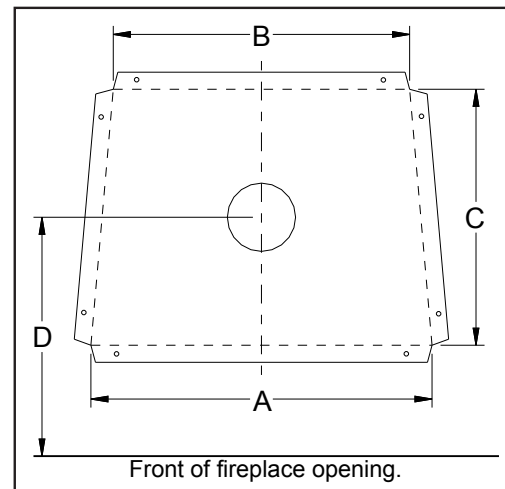

Figure 18: Layout of the Block-Off Plate.

INSTALLATION

the fireplace opening. Remove the template and cut a 6¼" diameter hole centered on this mark.

4. Using the template make the block-off plate of 24 gauge or thicker steel. Drill two (2) holes in each flange for mounting the plate.
5. Mount the block-off plate using masonry screws in a masonry fireplace and sheet metal screws on a zero-clearance fireplace (screws need only be long enough to penetrate the first layer of metal).
6. Insulate the block-off plate using high - temperature fiberglass insulation and furnace cement.
7. After installing the unit into place and the pipe through the block-off plate, use high - temperature fiberglass insulation and furnace cement to seal any gaps between the pipe and block-off plate (allow the cement to dry for at least 24 hours before burning).

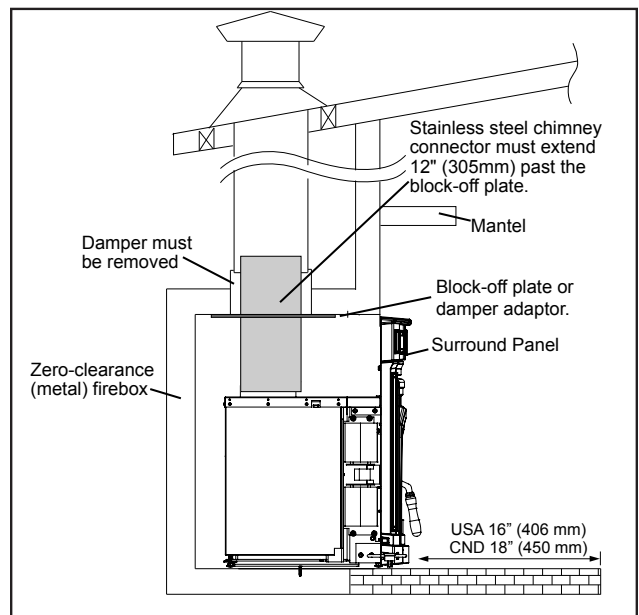

Figure 19: Insert Install into a Zero-Clearance Fireplace.

Zero Clearance Notes:

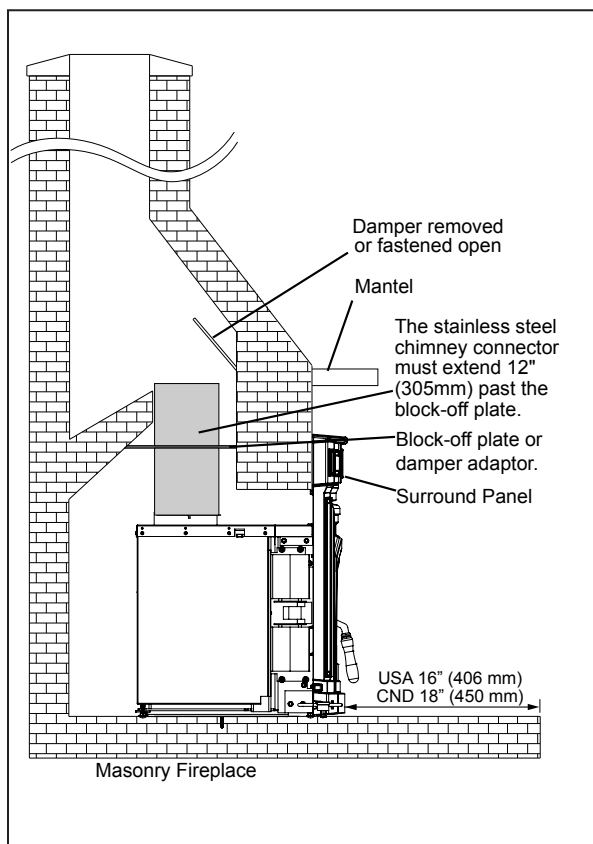

Fig. 20: Masonry Fireplace Direct Connection Insert

The fireplace must not be altered, except for the exceptions below. The permanent metal warning label provided must be attached to the back of the fireplace, stating that the fireplace may have been altered to accommodate the insert, and must be returned to original condition for use as a conventional fireplace. The following modification of factory built fireplaces are permissible: removal of damper, removal of smoke shelf or baffle, removal of ember catches, removal of fire grate, removal of viewing screen/curtain, and removal of doors. The factory built chimney must be listed per UL 127 (US), and meet type HT requirements of UL 103 (US). Factory built fireplace chimneys tested to UL 127-1998, may be at the fireplace manufacturer's option, tested to the same criteria as UL 103 HT requirements. If the chimney is not listed as meeting HT requirements, or if the factory built fireplace was tested prior to 1998, a full height listed chimney liner must be installed from the appliance flue collar to the chimney top. The liner must meet type HT requirements (2100°F) per UL 1777 (US). The liner must be securely attached to the insert flue collar and the chimney top. To prevent room air passage

to the chimney cavity of the fireplace, seal either the damper area around the chimney liner with high temperature sealant or the fireplace front with fiberglass batting.

INSTALLATION

MODEL 1200-C BRICK PLACEMENT & TUBE LOCATIONS:

COMPLETE THE STOVE AND CHIMNEY INSTALLATION BEFORE INSTALLING BRICKS.

1. Place the three (3) full size bricks along each side of the firebox and one (1) full size brick on either side of the back of the firebox.
2. To place the floor bricks, lay the two (2) partial bricks along the back of the floor. Then lay four (4) full size bricks in the front. The spaces between the bricks will soon fill with ashes.

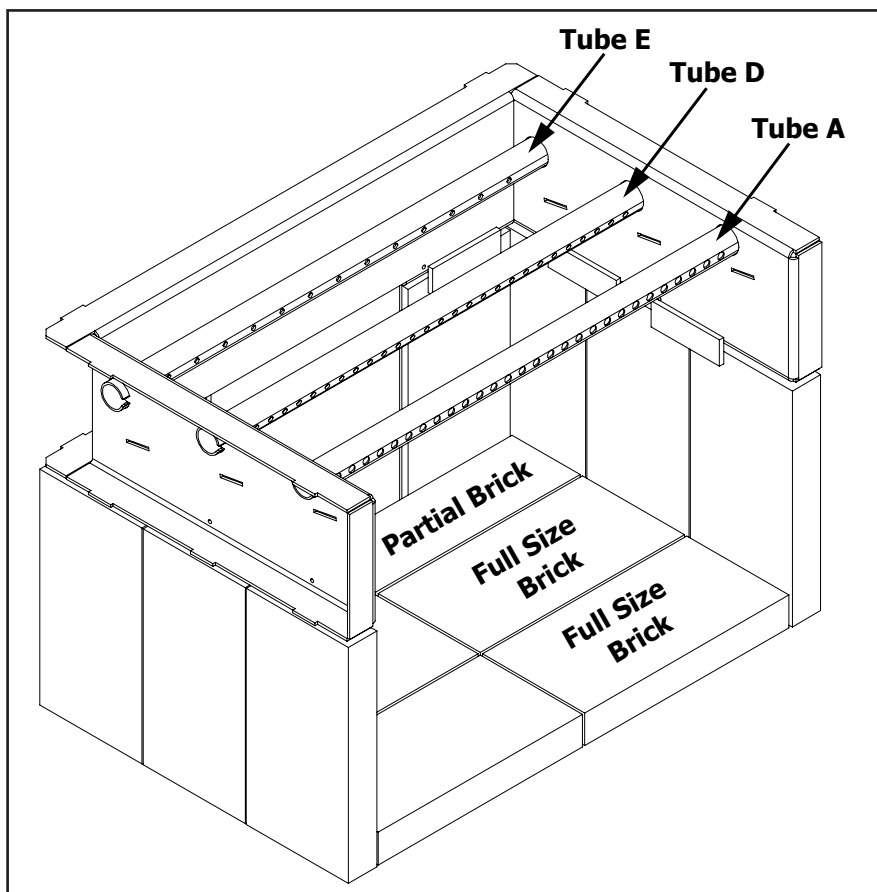

Figure 21: Brick Placement for 1200-C shown with Secondary Air Channel and Tubes.

When replacing bricks, use only pumice type fire bricks.

TOTAL BRICKS:

- | | |
|-----------------------|---|
| 12 - Full size bricks | 9" long x 4.5" wide x 1.25" thick
(22.9 cm long x 11.4 cm wide x 3.2 cm thick) |
| 2 - Partial bricks | 9" long x 3" wide x 1.25" thick
(22.9 cm long x 7.6 cm wide x 3.2 cm thick) |

Removing Air Tube: If a secondary air tube needs to be removed, place a screwdriver (any style except flat head) into one of the air holes and tap it with a hammer/mallet to the left until the right end of the tube is freed. To install a secondary air tube reverse the above instructions.

IMPORTANT: All secondary air tubes must be in place for proper operation.

INSTALLATION

MODEL 1700-C BRICK PLACEMENT & TUBE LOCATIONS:

COMPLETE THE STOVE AND SMOKE PIPE INSTALLATION BEFORE PLACING THESE BRICKS.

1. Place the four (4) full size bricks along each side of the firebox and one (1) full size brick on either side of the back of the firebox.
2. To place the floor bricks, lay the two (2) partial bricks along the back of the floor. Then lay six (6) full size bricks in the front. The spaces between the bricks will soon fill with ashes.

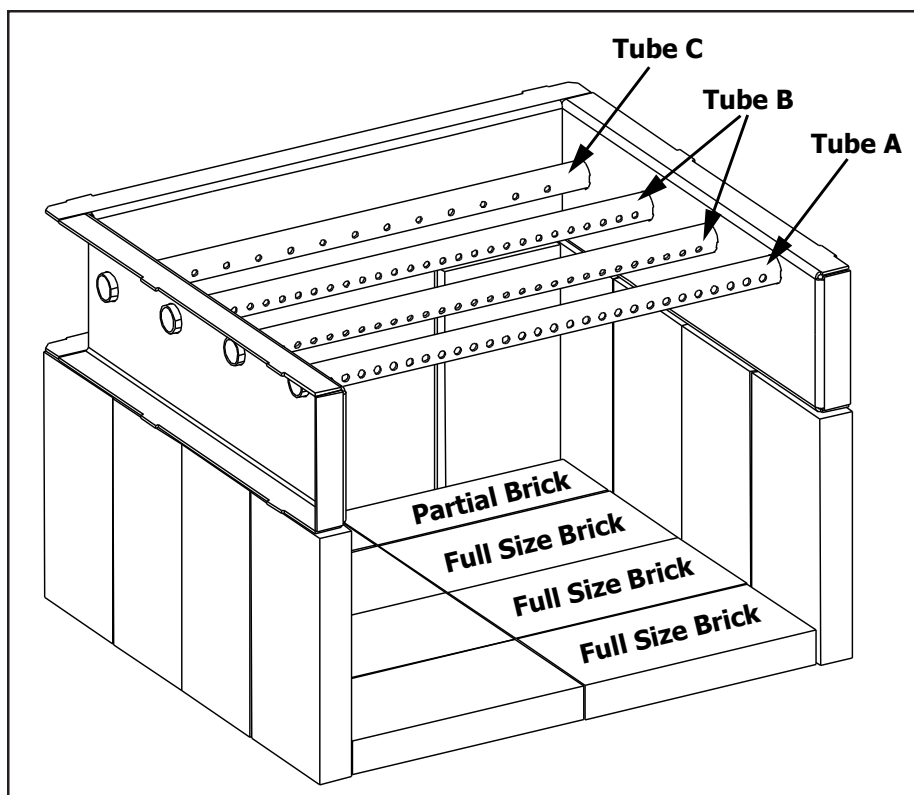

Figure 22: Brick Placement for 1700-C shown with Secondary Air Channel and Tubes.

When replacing bricks, use only pumice type fire bricks.

TOTAL BRICKS:

- | | |
|-----------------------|---|
| 16 - Full size bricks | 9" long x 4.5" wide x 1.25" thick
(22.9 cm long x 11.4 cm wide x 3.2 cm thick) |
| 2 - Partial bricks | 9" long x 3" wide x 1.25" thick
(22.9 cm long x 7.6 cm wide 3.2 cm thick) |

Removing Air Tube: If a secondary air tube needs to be removed, place a screwdriver (any style except flat head) into one of the air holes and tap it with a hammer/mallet to the left until the right end of the tube is freed. To install a secondary air tube reverse the above instructions.

IMPORTANT: All secondary air tubes must be in place for proper operation.

INSTALLATION

C-CAST CERAMIC BAFFLE INSTALLATION:

1. Slide the right C-Cast Ceramic Baffle in over the secondary air tubes at the top of the firebox. The tab must be on the top and pointing towards the center and the smooth side is to face down.
2. Hook the outside edge of the baffle over the top of the secondary air chamber. This will make room for the installation of the left C-Cast Ceramic Baffle.
3. Slide the left C-Cast Ceramic Baffle in over the secondary air tubes. The tab must be on the bottom and pointing towards the center and the smooth side is to face down.
4. Pull the baffles together in the middle so the right tab rests on top of the left tab. Ensure the baffles are flush with the back and both sides of the firebox.

Note: If the bolts on the flue collar are not to the left and right of the hole, the front secondary air tube will need to be removed in order to install or remove the C-Cast Ceramic Baffles. To remove the front secondary air tube place a screwdriver (any style except flat head) into one of the air holes and tapping it with a hammer/mallet to the left.

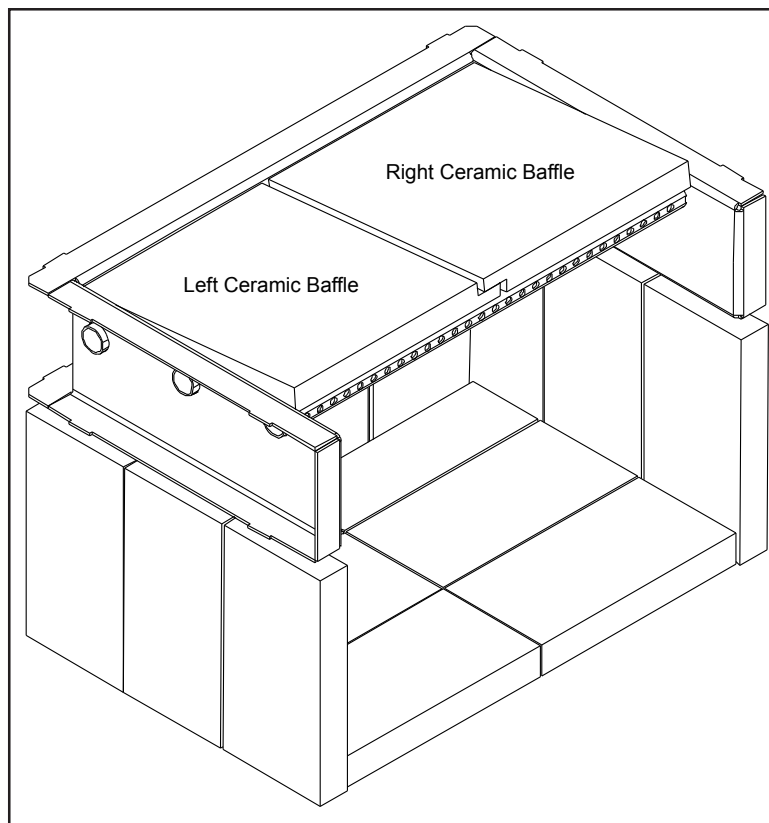

Figure 23: Installation of C-Cast Ceramic Baffle.

INSTALLATION

FAN WIRING DIAGRAM:

This appliance, when installed, must be electrically connected and grounded in accordance with local codes or in the absence of local codes, with the current CSA C22.1 CANADIAN ELECTRICAL CODE. Part 1, SAFETY STANDARDS FOR ELECTRICAL INSTALLATIONS, or THE NATIONAL ELECTRICAL CODE ANSI / NFPA 70 in the USA.

CAUTION Label all wires prior to disconnection when servicing controls. Wiring errors can cause improper and dangerous operation. Verify proper operation after servicing.

DO NOT oil the fan bearings.

DO NOT cut or remove the grounding prong from the plug.

DO NOT route the power cord beneath the heater.

WARNING: This appliance is equipped with a three-prong (grounding) plug for your protection against shock hazard and should be plugged into a properly grounded three-prong receptacle.

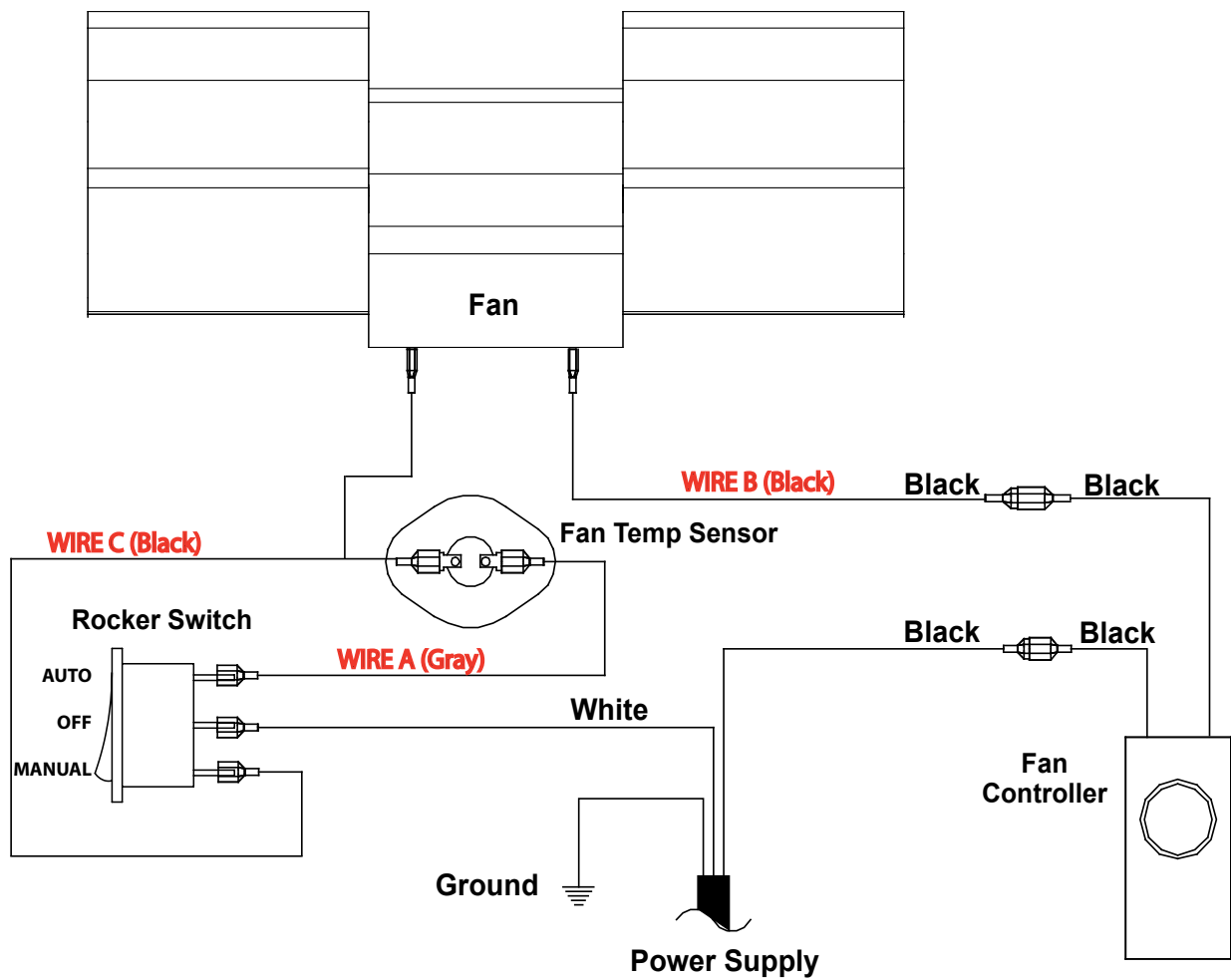

Figure 24: Fireplace Insert Fan Wiring Diagram.

DISASSEMBLY

CAUTION: ENSURE POWER CORD IS UNPLUGGED AND UNIT IS COLD BEFORE ATTEMPTING ANY DISASSEMBLY.

REMOVAL OF CAST TOP

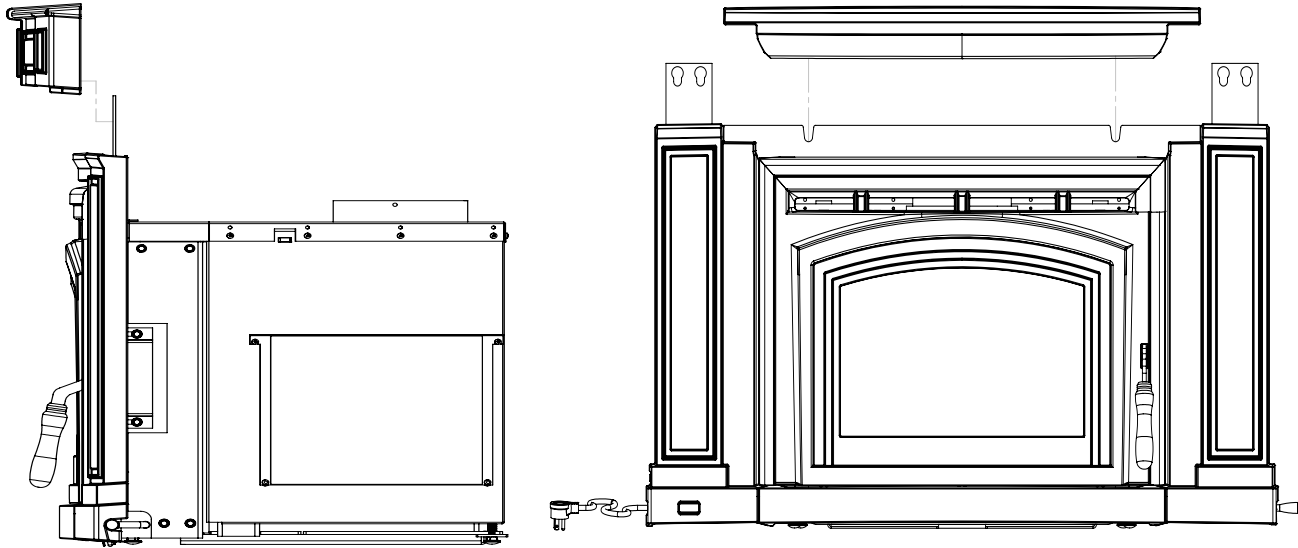

Figure 25: Removal of Cast Top Parts

1. Remove the three piece cast top from the unit by lifting up and forward. (For re-assembly, ensure that slots in the brackets are fully seated on the bolts)
2. Remove cast piece about door, lift straight up.

REMOVAL OF CAST DOOR

1. Fully open the door.
2. With the help of another person, lift the door straight up off the hinge pins.

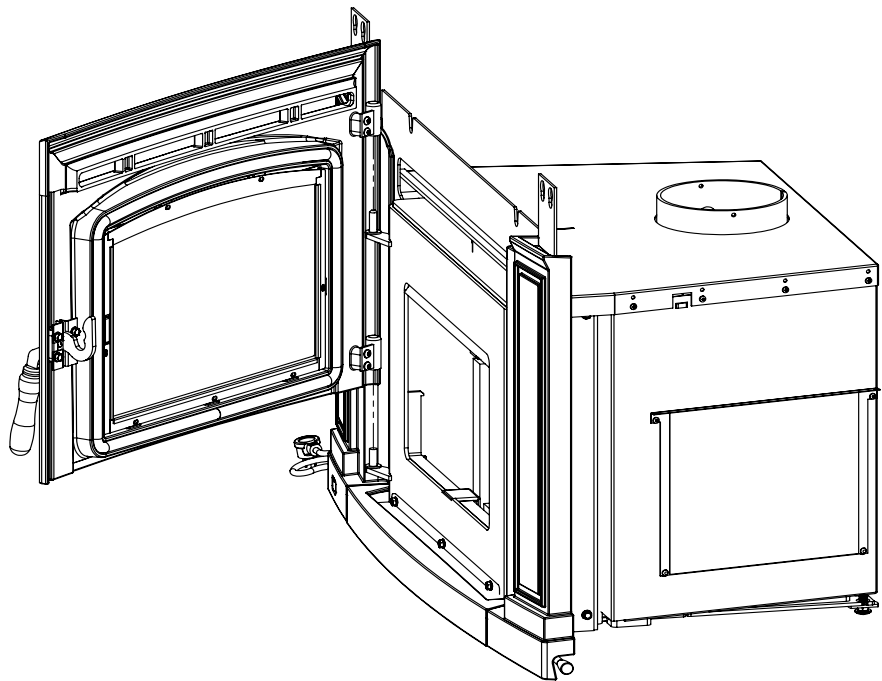

Figure 26: Removal of Door

DISASSEMBLY

REMOVAL OF THE CAST SIDE PANELS:

1. Lift cast sides straight up, then forward to remove. If sides are not moving, loosen (but do not remove) the three 1/4-20 screws on the side casting using a 3/8" wrench.
2. The Fan Controller assembly is mounted to Left Side Cast. For proper dis-assembly Wires connecting Fan Controller to fan need to be disconnected, or fan controller assembly can be removed from the Left Side Cast by removing two T-20 screws (see next page).

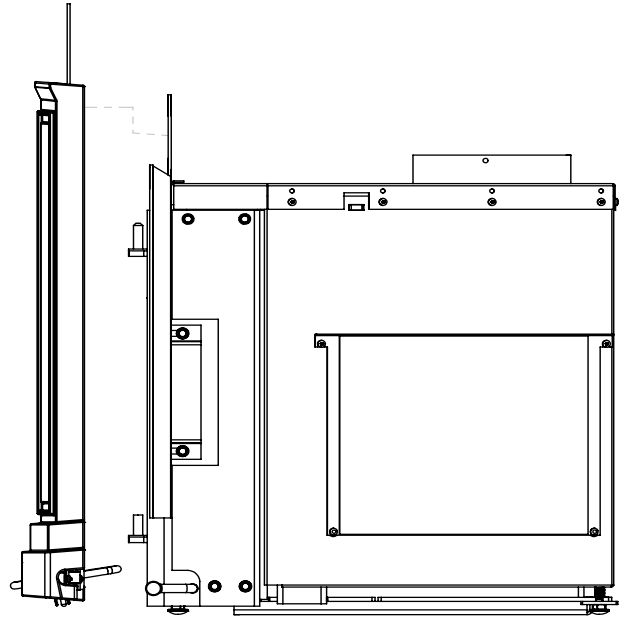

Figure 27: Cast Side Panel Screws

REMOVAL OF LOWER FRONT CASTING

1. Lift Cast Bottom straight up and out to remove. Notice key slot attachments.

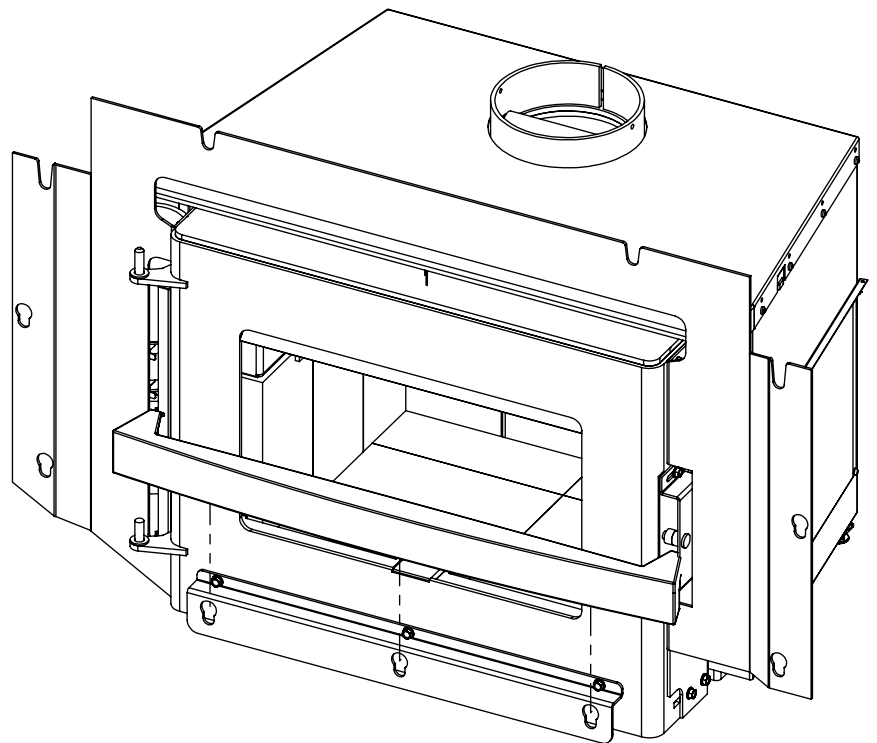

Figure 28: Cast Bottom Removal

DISASSEMBLY

REMOVAL OF CAST SIDE BRACKET

1. Use a 3/8" socket to remove the four screws holding the cast side mounting bracket to the firebox.
2. Lift the bracket up and out to remove it.

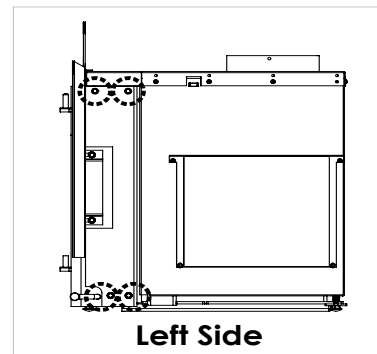
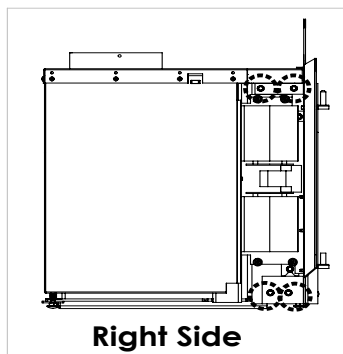
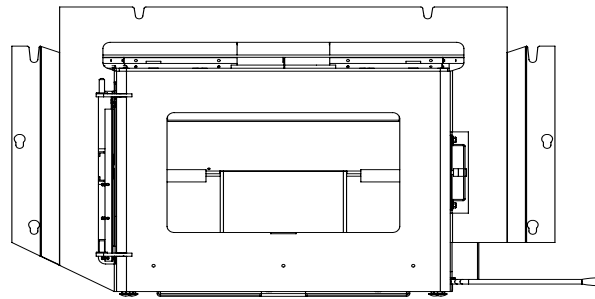

Figure 29: Lower Front Casting Removal

REMOVAL OF FAN ASSEMBLY

1. Once all castings and mounting brackets have been removed you are able to access the fan.
2. Unplug the wires coming from the fan. A light wiggle will help loosen the connectors.
3. Use a 3/8" socket to remove the two 1/4" bolts. The entire fan assembly can now be removed.

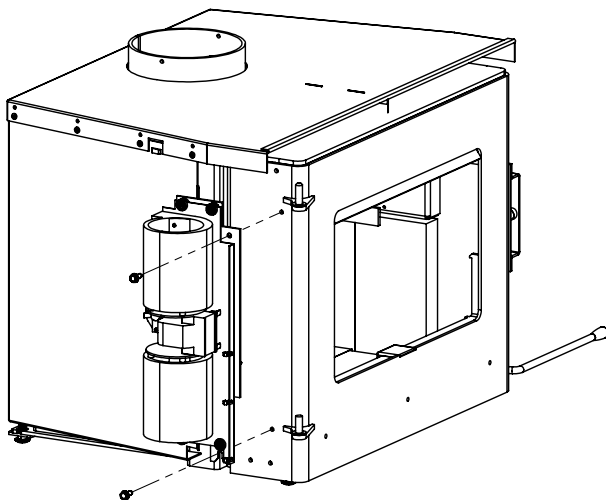

Figure 30: Fan Removal

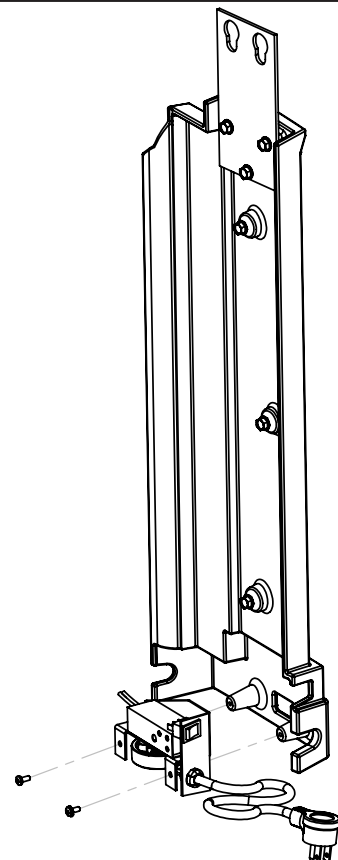

Figure 31: Fan controller removal

DISASSEMBLY

DOOR LATCH ADJUSTMENT:

Over time as the door gasket fully compresses to the face of the firebox, it may be necessary to adjust the door latch position to maintain a tight seal. Signs that the door latch may need adjusting are if the door handle feels overly loose when closed, or if you notice wood is being burnt faster than normal.

1. Follow the disassembly steps from Figures 25-28 (Right side only).
2. Use a 3/8" socket to loosen the two 1/4" bolts and slide the latch slightly back. Retighten the bolts and latch the handle. The handle should provide a bit of resistance and close firmly.

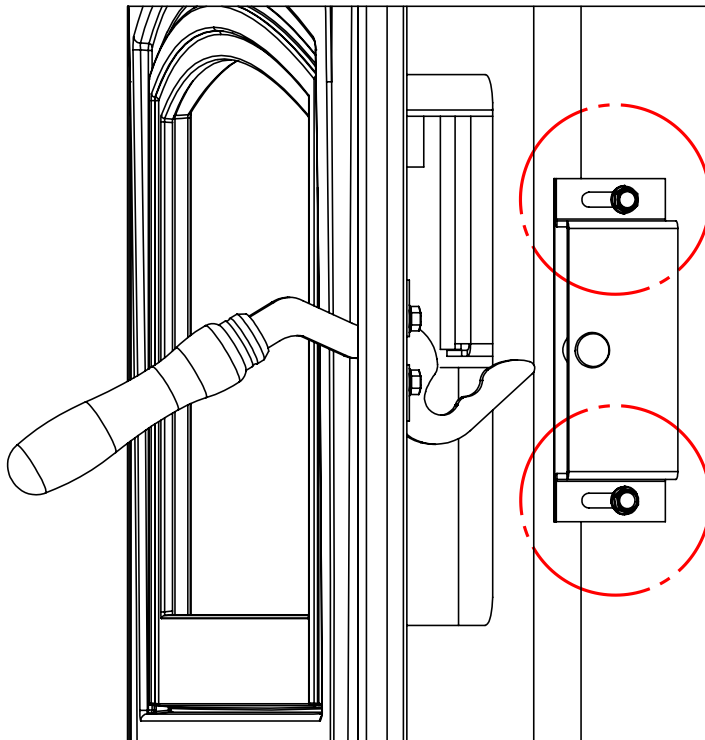
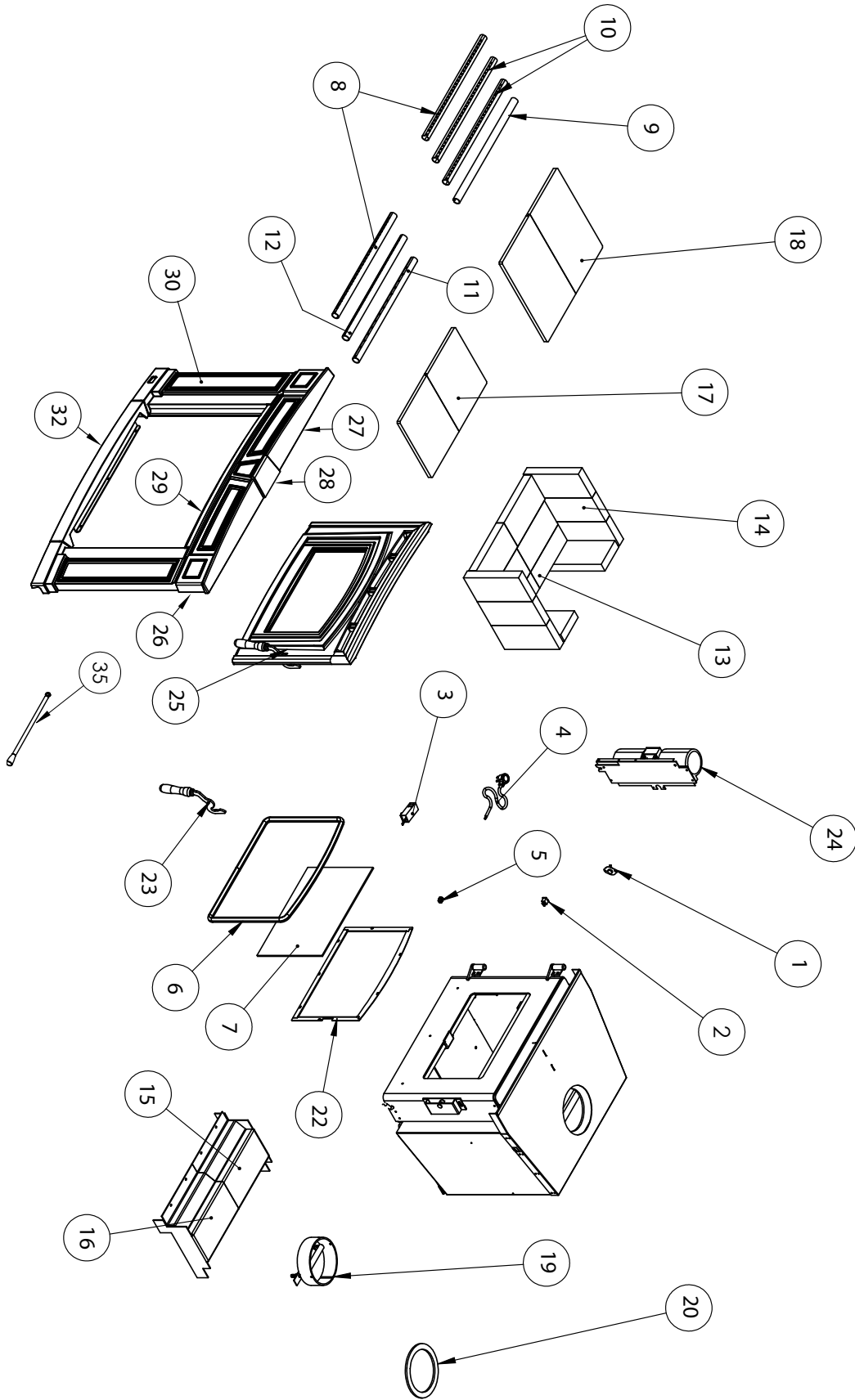

Figure 32: Latch Adjustment

PARTS DIAGRAM



PARTS LIST

Reference #	Description	Part #
1	120 CERAMIC FAN TEMP SENSOR (ALL MODELS)	EC-001
2	FPI BURNER SWITCH	EC-026
3	WOOD INSERT FAN CONTROLLER (75V) 115V	EC-039
4	DOMESTIC POWER CORD (115V)	EC-042
5	HEYCO STRAIN RELIEF	EC-044
6	WOODSTOVE DOOR GASKET (7FT)	EF-168
7	EFW GLASS WITH TAPE	10-000
8	1200 & 1700 FRONT SECONDARY AIR TUBE A	50-1099
9	1700 REAR SECONDARY AIR TUBE C	50-1100
10	1700 MID SECONDARY AIR TUBE B	50-1101
11	1200 REAR SECONDARY AIR TUBE E	50-1102
12	1200 MID SECONDARY AIR TUBE D	50-1103
13	PUMICE BRICKS 3 X 9	50-1104
14	PUMICE BRICKS 4.5 X 9	50-1105
15	1200/1700 LEFT SHIELD ASSEMBLY	50-1144
16	1200/1700 RIGHT SHIELD ASSEMBLY	50-1145
17	1200 CERAMIC BAFFLE - L/R SET	50-1146
18	1700 CERAMIC BAFFLE - L/R SET	50-1147
19	1200/1700 FPI INSERT FLUE COLLAR ASSEMBLY	50-1148
20	WOOD CERAMIC FLUE GASKET	50-1413
21	FPI ANGLED FLUE COLLAR	50-1565
22	WOOD DOOR GLASS RETAINER KIT (WITH SCREWS)	50-1122
23	BOSTON DOOR HANDLE COMPLETE	50-2393
24	CABELLO FPI REPLACEMENT FAN ASSEMBLY	50-2669
25	CABELLO DOOR ASSEMBLY (NO HANDLE)	50-2670
26	CABELLO CAST TOP RIGHT-PD	50-2671
27	CABELLO CAST TOP LEFT-PD	50-2672
28	CABELLO CAST KEYSTONE-PD	50-2673
29	CABELLO CAST TOP-PD	50-2674
30	CABELLO CAST SIDE LEFT-PD	50-2675
31	CABELLO CAST SIDE RIGHT-PD	50-2676
32	CABELLO CAST BOTTOM-PD	50-2677
33	CABELLO CAST SURROUND COMPLETE-PD	50-2678
34	1200/1700 CABELLO O/S FILLER PANEL (36" x 46")	50-2613
35	CABELLO DAMPER ROD C/W KNOB AND NUT	50-2770
	CABELLO OWNER'S MANUAL	50-2627

RATING LABEL



Tested & Listed By
O-TL Chimneys
Portland Oregon USA

DO NOT REMOVE THIS LABEL / NE PAS ENLEVER CETTE ÉTIQUETTE

LISTED SOLID FUEL SPACE HEATER / IDENTIFIÉ COMME UN FOYER A COMBUSTIBLE SOLIDE

Model / Modèle: Cabello 1200 FPI Cabello 1700 FPI

Report/Rapport no. 268-S-06c-2

Serial No. / No. De Série:

Certified for use in Canada & USA / Certifié pour installation au Canada et aux États-Unis

Tested to ULC-S628-93, & UL-1482-11. / Testé selon ULC-S628-93, & UL-1482-11.

US Environmental Protection Agency, certified to comply May 15, 2015, particulate emission standards. / États-Unis Environmental Protection Agency, a certifié pour conformer au Mai 15, 2015, les normes de particules d'émission.

Ce dispositif doit être installé et opéré conformément aux instructions d'installation et d'opération du fabricant. Contactez le service local de l'inspection des bâtiments ou l'officier pompier concernant les restrictions et l'inspection d'installation dans votre localité. Utilisez des connecteurs repositionnés 24 MSG noir ou 25 MSG en acier brossé de 6" (150 mm) minimum, et une cheminée de fabrication industrielle, appropriée pour utilisation avec des combustibles solides ou avec une cheminée de maçonnerie. Vérifiez les précautions à prendre exigées par le code local et les instructions du fabricant concernant les conditions pour passer la cheminée à travers un mur ou un plafond combustible. Ne pas installer le connecteur de la cheminée à travers un mur ou un plafond combustible. Espaces libres minimum d'un connecteur horizontal et plafond sont 18" (455 mm) ne pas connecter ce dispositif à un conduit de cheminée qui sert déjà un autre dispositif.

Models 1200 and 1700 inserts may be installed as an insert in a masonry fireplace. / On peut encaster le modèles 1200 et 1700 dans un foyer de maçonnerie.

T FLOOR PROTECTION / PROTÉGER LE PLANCHER:
If unit is raised / Si l'appareil est soulevé:
0" - 2" (0mm - 51mm); 1" (25mm) non-combustible material with k value = 0.84 or equivalent / 1" (25mm) le matériel incombustible avec la valeur de k = 0.84 ou équivalent.
2" - 8" (51mm - 203mm); ½" (13mm) non-combustible material with k value = 0.24 or equivalent / ½" (13mm) le matériel incombustible avec la valeur de k = 0.24 ou équivalent.
Greater than/Plus grand que 8" (203 mm) any non-combustible material / n'importe quel type de matériel incombustible.

Model / Modèle	1200 FPI	1700 FPI
A To unshielded side wall / aux mur non protégé	14" (356 mm)	14" (356 mm)
B To an unshielded 8" (203 mm) mantle / aux manteau 8" non protégé	21" (533 mm)	24" (610 mm)
C To top being (protruding ½" (19 mm)) clearance / aux revêtement supérieur	17½" (445 mm)	19½" (495 mm)
D To side facing (protruding ½" (19 mm)) clearance / aux revêtement à côté	1" (25 mm)	1" (25 mm)
E T From door opening of unit to edge of floor protection / De ouverture de la porte de l'unité à bord de la protection de plancher	USA 16" (406mm) / CND 18" (450mm)	
F T From side of unit to edge of floor protection / Du côté de l'unité au bord de la protection de plancher	USA 6" (152 mm) / CND 8" (200 mm)	

OPERATE ONLY WITH DOORS CLOSED. Only open door to feed fire. For use with solid wood fuels only. Do not use any other type of fuel. Do not use grate or elevate-fire build wood fire directly on hearth. Do not overfire. Do not obstruct beneath the heater. If heater or chimney connector glows, you are overfiring. Inspect and clean chimney frequently-under certain conditions of use, creosote buildup may occur rapidly. The provided insulation materials are required for operation. Keep furnishing and other combustibles well away from heater. Replace glass only with 5 mm thick ceramic glass. Optional component for FS: fan, electrical rating 115V, 60 Hz 1 Amp (Part # EFW-261). Combustion air openings are not to be obstructed.
Danger: Risk of electrical shock. Disconnected power before servicing unit. Route cord away from heater.



HOT WHILE IN OPERATION. DO NOT TOUCH. KEEP CHILDREN, CLOTHING AND FURNITURE AWAY. CONTACT MAY CAUSE SKIN BURN, READ NAMEPLATE AND INSTRUCTIONS.

MANUFACTURED BY: FABRIQUE PAR: SHERWOOD INDUSTRIES LTD. 6782 OLDFIELD ROAD, SAANICHTON, BC CANADA

MISE EN GARDE: TRÈS CHAUD QUAND ALLUMÉ. LES ENFANTS, LES VÊTEMENTS ET LES MEUBLES. LE CONTACT PEUT CAUSER DES BRÛLURES. LISEZ ATTENTIVEMENT L'ÉTIQUETTE ET LES INSTRUCTIONS.

DATE OF MANUFACTURE / DATE DE FABRICATION: J F M A M J J A S O N D 2015 2016 2017 2018 2019

U.S. ENVIRONMENTAL PROTECTION AGENCY Certified to comply with 2015 particulate emission / ENVIRONMENTAL PROTECTION AGENCY US conforme aux normes 2015 d'émission de particules. Non approuvé pour

C-14617

Figure 33: Rating Label Sample

ELECTRICAL SHOCK LABEL

ELECTRICAL SHOCK LABEL LOCATED ON/NEAR ELECTRICAL CORD:

DO NOT REMOVE THIS LABEL / NE PAS ENLEVER CETTE ÉTIQUETTE
LISTED SOLID FUEL SPACE HEATER / IDENTIFIÉ COMME UN FOYER À COMBUSTIBLE SOLIDE

DANGER! Risk of Electrical Shock.
Disconnect Power Before Servicing Unit.

ATTENTION! Risque de choc électrique.
Débranchez l'alimentation avant l'Unité des services.

WARNING!

Electrical Grounding Instruction
This appliance is equipped with a three-prong (grounding) plug for your protection against shock hazard and should be plugged directly into a properly grounded three-prong receptacle. **DO NOT** cut or remove the ground prong from this plug.



AVERTISSEMENT!

Instruction mise à la terre électrique
Cet appareil est équipé d'un à trois broches (terre) pour votre protection contre les risques de choc électrique et doit être branché directement dans une prise à trois broches prise. **NE PAS** couper ou enlever la broche de terre de cette fiche.

C-13894

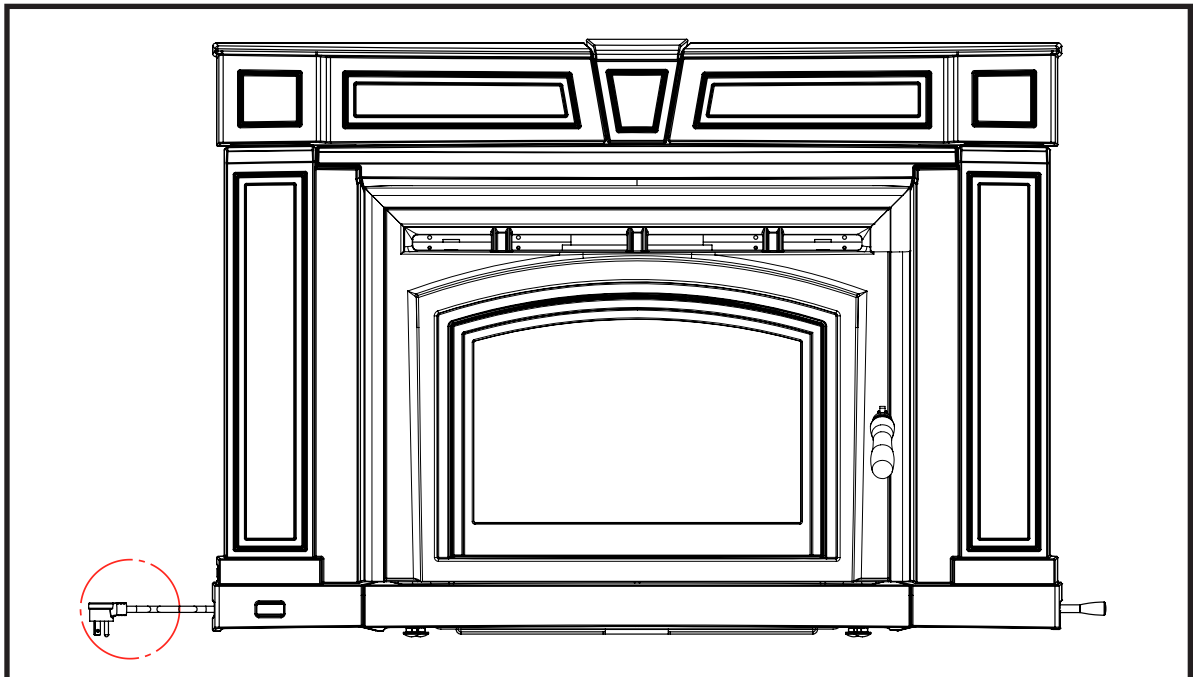

Figure 34 Electrical Shock Label Location

NOTES



Warranty for Enviro Wood Products

Sherwood Industries Ltd. ("Sherwood") hereby warrants, subject to the terms and conditions herein set forth, this product against defects in material and workmanship during the specified warranty period starting from the date of original purchase at retail. In the event of a defect of material or workmanship during the specified warranty period, Sherwood reserves the right to make repairs or to assess the replacement of a defective product at Sherwood's factory. The shipping costs are to be paid by the consumer. All warranties by Sherwood are set forth herein and no claim shall be made against Sherwood on any oral warranty or representation.

Conditions

- A completed warranty registration must be submitted to Sherwood within 90 days of original purchase via the online warranty registration page or via the mail-in warranty registration card provided. Have the installer fill in the installation data sheet in the back of the manual for warranty and future reference.
- This warranty applies only to the original owner in the original location from date of install.
- The unit must have been properly installed by a qualified technician or installer, and must meet all local and national building code requirements.
- The warranty does not cover removal and re-installation costs.
- Sherwood Industries Ltd. reserves the right to make changes without notice.
- Sherwood Industries Ltd. and its employees or representatives will not assume any damages, either directly or indirectly caused by improper usage, operation, installation, servicing or maintenance of this appliance.
- A proof of original purchase must be provided by you or the dealer including serial number.

Exclusions

An expanded list of exclusions is available at www.enviro.com/help/warranty.html

This warranty does not cover:

- Damage as a result of improper usage or abuse.
- Damage caused from over-firing due to incorrect setup or tampering.
- Damage caused by incorrect installation.

To the Dealer

- Provide name, address and telephone number of purchaser and date of purchase.
- Provide date of purchase. Name of installer and dealer. Serial number of the appliance. Nature of complaint, defects or malfunction, description and part # of any parts replaced.
- Pictures or return of damaged or defective product may be required.

To the Distributor

- Sign and verify that work and information are correct.

Sherwood Industries Ltd.

6782 Oldfield Road, Victoria, BC . Canada V8M 2A3
 Online warranty registration: www.enviro.com/warranty/

Category	One Year	Two Year	Limited Lifetime (7yr)
Parts ¹ (unit serial number required)		✓	
Firebox (excluding bricks) ²			✓
Ceramic Baffle ³			✓
Secondary Air Tubes			✓
Surround Panels (excluding finish)			✓
Pedestals / Legs (excluding finish)			✓
Ceramic Glass ⁴	✓		
Door Assembly (excluding gasket)			✓
Slider Control			✓
Shield Assembly			✓
Electrical Components		✓	
Convection Fan		✓	
Exterior Surface Finishing ⁵	✓		
Gasket	✓		
Labour		✓	

¹ Whereas warranty has expired, replacement parts will be warranted for 90 days from part purchase date. Labour not included. Unit serial number required.

² Warranty does not cover damage caused from burning artificial/firestarter log varieties.

³ Excludes damage caused by loading wood, cleaning or service.

⁴ Glass is covered for thermal breakage. Photos of box, inside of door, and unit serial # must be supplied for breakage due to shipping.

⁵ Exterior Surface finishing covers Plating, Enamel or Paint and excludes colour changes, chipping, and fingerprints.

Travel costs not included.

No warranty on replacement firebricks

INSTALLATION DATA SHEET

The following information must be recorded by the installer for warranty purposes and future reference.

NAME OF OWNER: _____
ADDRESS: _____ _____ _____
PHONE: _____

NAME OF DEALER: _____
ADDRESS: _____ _____ _____
PHONE: _____

MODEL: _____
SERIAL NUMBER: _____
DATE OF PURCHASE: _____(dd/mm/yyyy)
DATE OF INSTALLATION: _____(dd/mm/yyyy)
INSTALLER'S SIGNATURE: _____

NAME OF INSTALLER: _____
ADDRESS: _____ _____ _____
PHONE: _____

MANUFACTURED BY:
SHERWOOD INDUSTRIES LTD.
6782 OLDFIELD RD. SAANICHTON, BC, CANADA V8M 2A3
www.enviro.com
October 28, 2015
C-14580